



# Water Transport Trailers

## Water Trailer

The 1010 EP-DOT Series Trailer allows you to transport water safely while legally driving on state roads. Each trailer is equipped with a Honda® engine, a Banjo® pump and a DOT light kit (lights, brakes & fenders that comply with DOT standards). The 1,010 gallon DOT trailers feature the tank Pin Mount™ system.

Ideal for commercial, construction, and industrial applications.

## Dependable Water Transportation

Durable and reliable, this water tank and trailer package is fully compliant with DOT regulations.

- **Hose Mounted Reel**
- **Comes with Pressurized Garden Hose Bib**
- **Includes Suction and Discharge Hose**
- **Warranty**
  - ◊ **10 Year Tank**
  - ◊ **3 Year Honda 5.5 hp Engine**
  - ◊ **1 Year Water Pump**
  - ◊ **1 Year Trailer Frame**
- **Rear Spray Dust Nozzles**



# EP-DOT Water Trailer - 1010 gallon

Length	195"
Width	73"
Height	78"
Hose Size	2"/Black Fertilizer
Size (US Gallons)	1,010
Dry Weight (lbs)	1,650
Tires	235/80 R16 10 PLY DOT Tire & Wheel
DOT Compliant	Yes
Frame Construction	6" x 2" Rectangle Tubing
Axle (s)	2 x 7,000 lbs. Slipper Spring
Tank Type	Poly sump bottom transport tank
Hitch Type	20,000 lbs. 2-5/16" Ball
Brakes	Electric with emergency breakaway (2 x Axle)
Fenders	Yes
Electrical Plug	7 Pole RV Plug
Motor	Honda® GX160 5.5 HP
Pump	2" Banjo® Centrifugal Poly, 195 GPM
Valve Fittings	2" Banjo® sweep manifold
Lights	DOT compliant clearance, stop, turn, tail, license



# EP-DOT Water Trailer - 1010 gallon

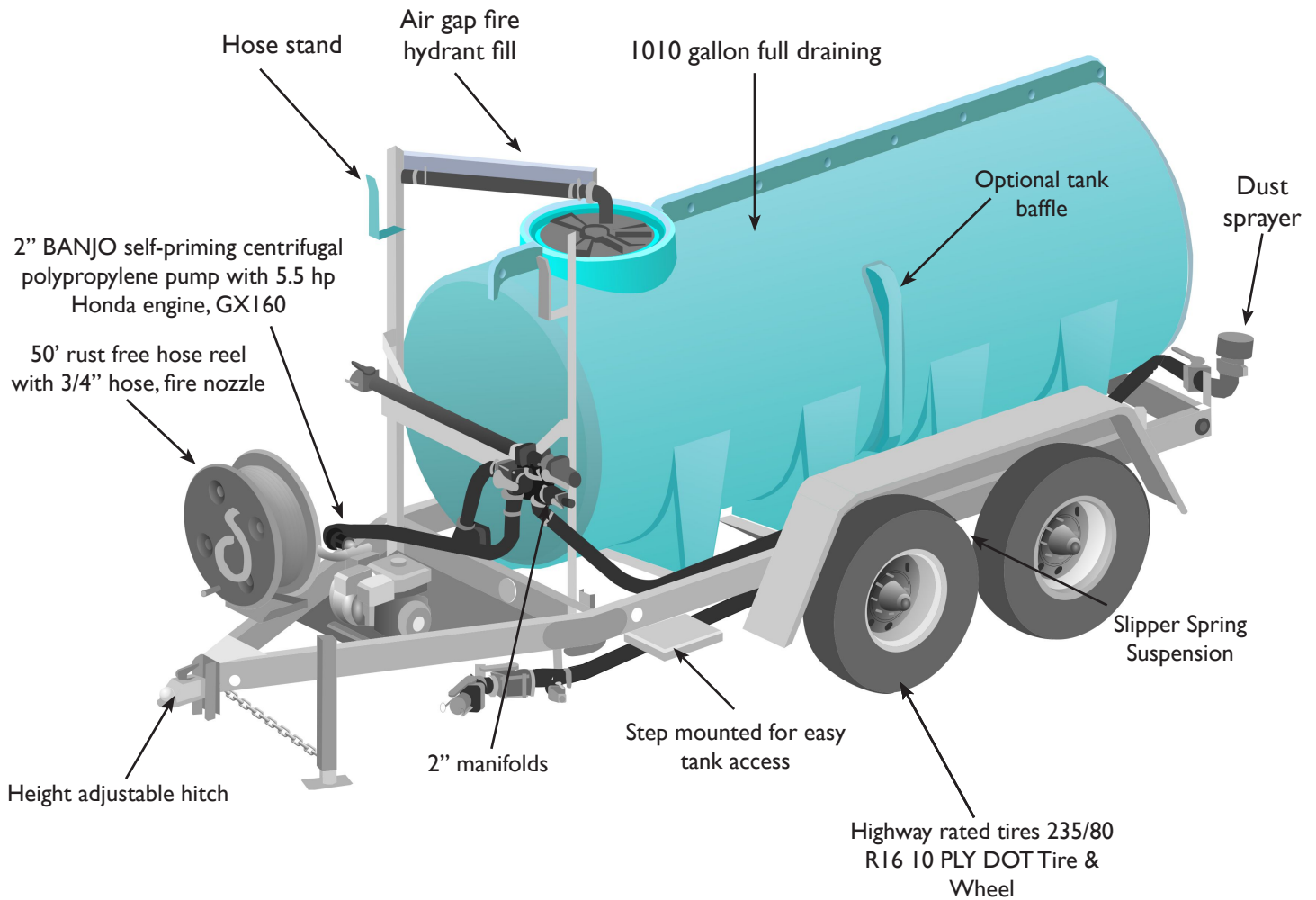

## Features

- Electric Brakes, Fenders, & LED Lighting
- 5.5 hp Honda GX160 engine
- 2" Banjo Self-Priming Centrifugal Polypropylene Pump, 195 gpm/45 psi
- Highway Rated 235/80 R16 10 PLY DOT Tires & Wheels
- 50' Rust Free Hose Reel with 3/4" Hose, Fire Nozzle
- Adjustable Hitch
- Optional Water Tank Baffle

## Benefits

- Fully DOT Compliant for Public Roadway Transportation
- Small Turning Radius and Easy to Maneuver
- Built for Heavy Hauling, On or Off Road
- Designed for Stable Weight Distribution
- Low Maintenance
- Controlled Water Use
- Sprays Water Where You Need It

# EP-DOT Water Trailer - 1010 gallon

**LIFTING-LUGS™**  
Built-in and engineered to take the \*weight of the tank, these make lifting the tank on and off the trailer a breeze. \*Dry Weight Only

**ANTI-SPLASH™ STAINLESS LID**  
Lockable and spill-proof, this lid keeps liquid in while traveling on rough terrain. (Only on tanks 1,600 gallons and larger).

**THICK-WALL™ DESIGN**  
Extra-thick walls provide unmatched strength and durability.

**ROTO-MOLD CONSTRUCTION**  
When cooked and cooled at an even rate, the raw material is bonded together to make this tank virtually indestructible.

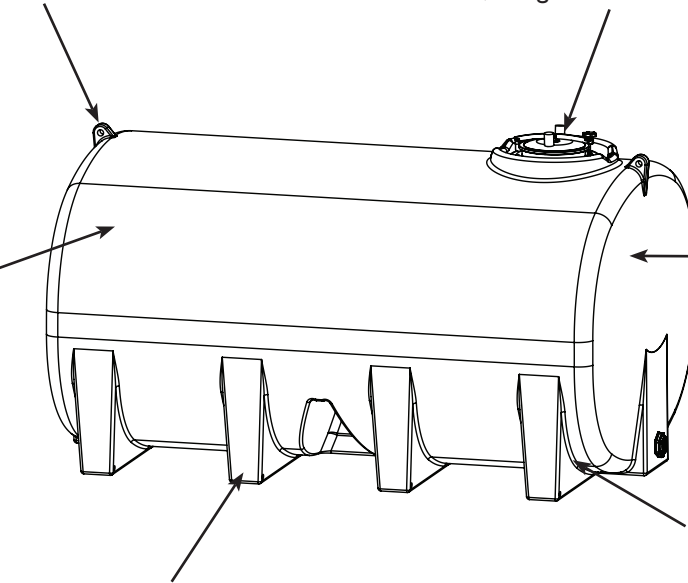

**SINGLE-PIECE™ CONSTRUCTION**  
Rotationally-molded in a single mold means the tank is seamless, water-tight and leak-proof.

**PIN-MOUNT™ SYSTEM**  
The molded-in mounting lugs combined with heavyduty steel pins will keep this tank fixed without movement. No hoops. No bands. No maintenance.

## Freight savings, shorter lead times, delivered fully assembled

There's no need to wait for the ridiculous lead times of today's world - we always keep a supply of the EP-DOT trailers in production.

