



Arena Water Trailer

Superior Dust Control

Arena Dust Control Trailer

Moistens dirt and maintains dust control, keeping your competition area safe. Sprayer creates the proper dirt consistency and precise moisture needed for a level, dust-free surface. Ensure reliable, consistent footing and rider safety with our heavy-duty arena water trailers.

The Right Water Trailer

Consistent water distribution is vital for both indoor and outdoor arenas. Use to moisten dirt for your arena groomer or controlling dust on the roads and parking lots around your facility. Ideal for:

- Horse arenas
- Arena dirt packing
- Stall cleaning and spraying
- Dog racing tracks
- Motocross
- Cleaning arena drags
- Go-kart facilities



Importance of Arena Maintenance

For indoor and outdoor arenas to stay at their peak, keeping them well-maintained is essential. Arenas provide horses with the right amount of cushion, good traction, and minimal dust. The base of the horse arena can last a decade, but care and maintenance affects its durability.



Maintaining moist footing is essential in a riding arena. The stability of the footing is dependent on routine watering, which helps bond sand fibers together and contributes to optimal arena conditions. Keeping your arena at its best helps eliminate inconsistencies, keeps the arena dust-free, and builds confidence in your horses.

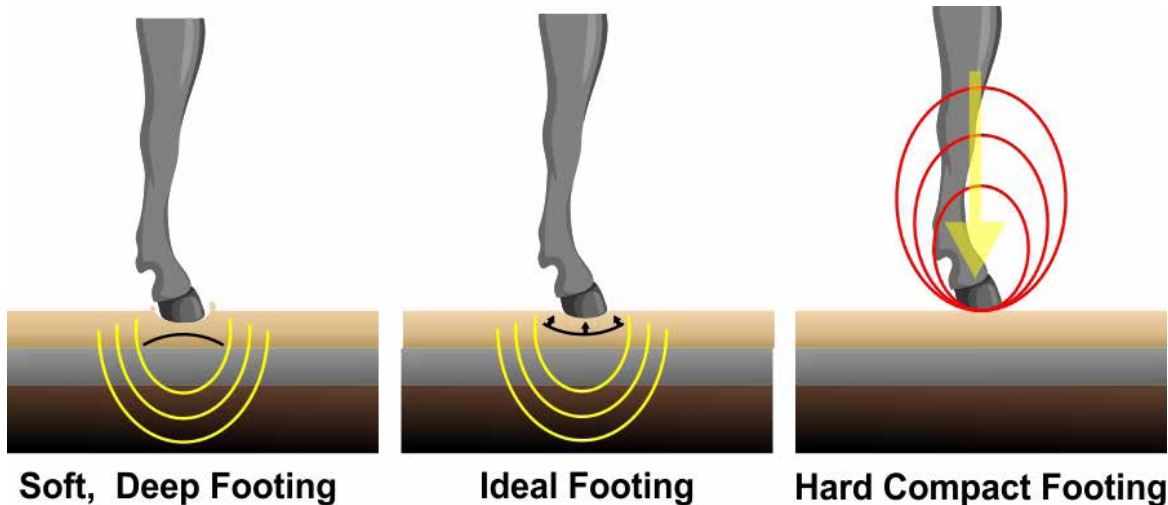

For more complete information on One Clarion products and solutions, visit us on the web at: www.clarionmunicipal.com or call us at : (+1) 863-261-8388 | info@oneclarion.com

© 2023 One Clarion. All rights reserved. One Clarion terms and conditions apply.



300 Gallon AquaDot Arena Water Trailer

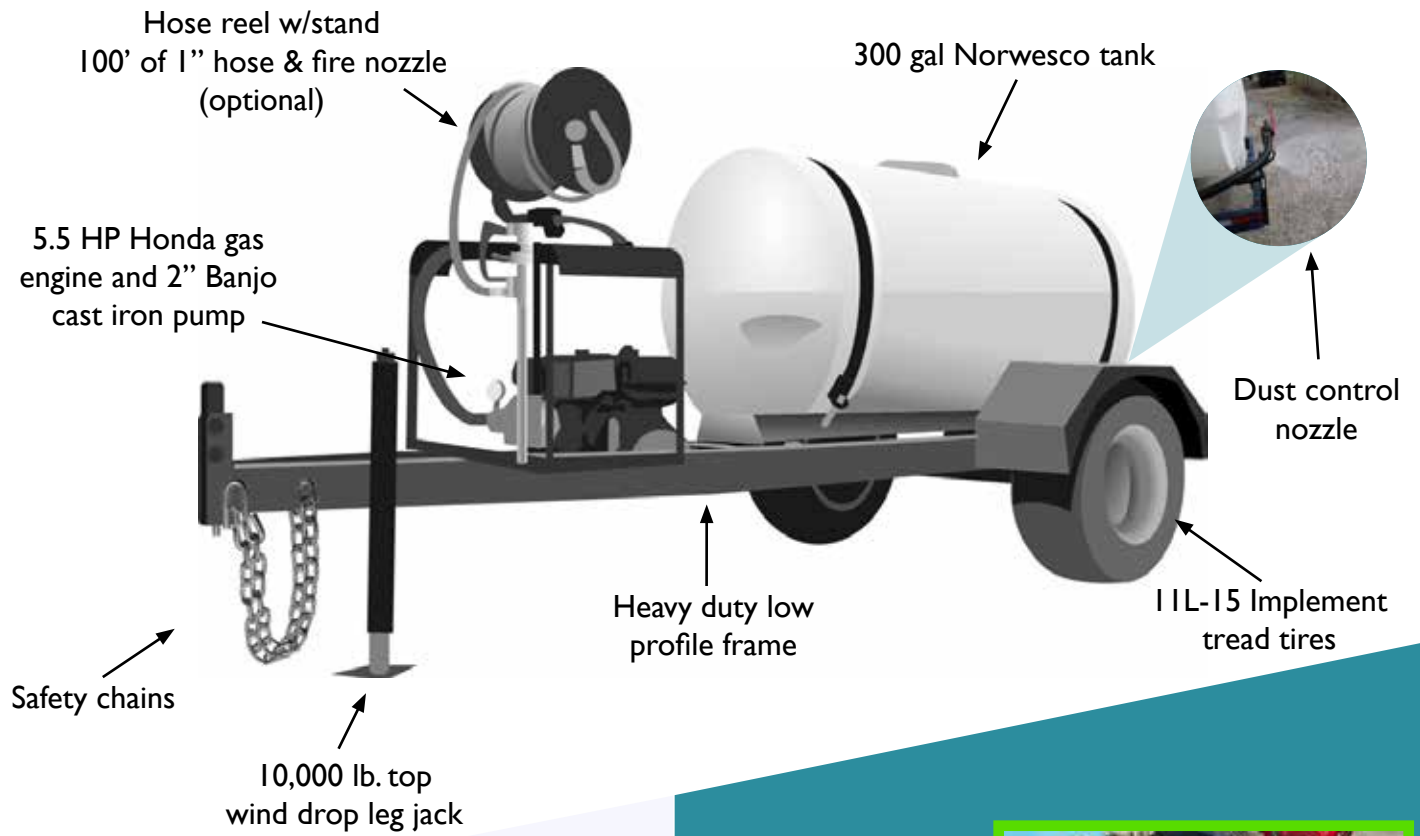

Features & Benefits

- Easy transportation around facilities
- Manuverable to reach tight spaces
- Quickly cleans stall and parking areas
- Standard or adjustable hitch



ONE
CLARION

SPECIFICATIONS

300 Gallon AquaDot Arena Water

Product Number: OC AquaDot-Arena Water Trailer 300 Gallon -Non DOT

Tank: 300 gal Norwesco tank

Frame: Heavy duty low profile, Powder coated painted

Engine & pump: 5.5 HP Honda gas engine, 2" Banjo cast iron pump

Tires: 11L-15 Implement tread tires

Jack: 15" Jack

Safety chains

Hitch: Choice of adjustable height hitch or standard clevis hitch

Warranty: 5 year frame warranty, 3 year non-prorated warranty on tank

Spraying: Rear dust control nozzle

Size & Weight: 126"(L) x 54"(H) x 83" (W), Dry weight and tank- 900 lbs



Includes:

- 3-year non-prorated warranty tank
- 5.5 HP GX160 Honda engine and 2" Banjo cast iron pump
- Recirculation plumbing kit control the proper volume of water flow to nozzle or hose bibb.
- Dust control nozzle -Stainless steel spray nozzle is adjustable from 8' wide to 35' . Spray approximately 25' deep from the rear.
- Hose bibb KIT - Pressure side, valve and 3/4" MGHT fitting - Hose bibb connection to attach garden hose if needed.

500 Gallon Elliptical AquaDot Dust Control

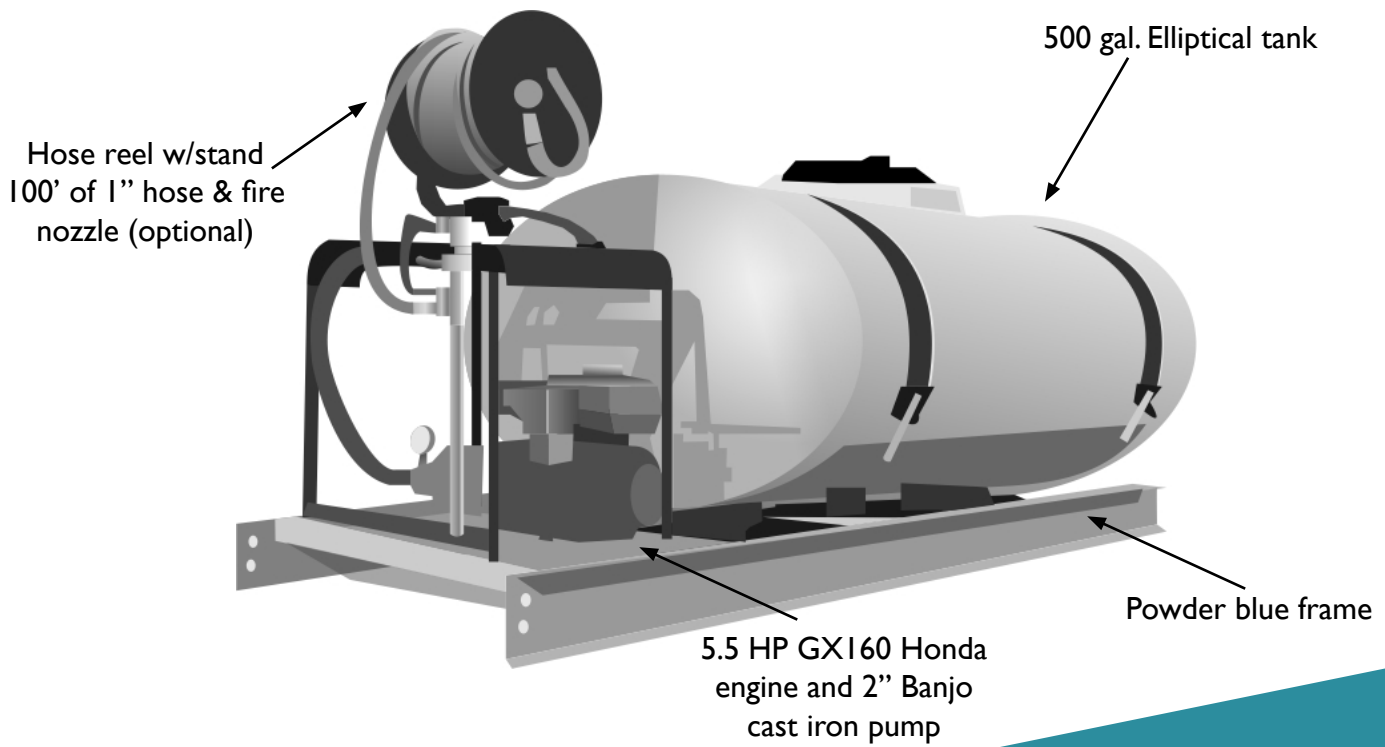

Consistent, Reliable Control

Maintain your entire arena complex. Our versatile skid sprayers can easily be loaded in UTVs, ATVs, trailers or pickup trucks to use anywhere in your arena.



ONE
CLARION

SPECIFICATIONS

500 Gallon Elliptical AquaDot Dust Control Skid

Product Number: OC AquaDot Elliptical Arena Skid 500 Gallon

Tank: 500 gal. Elliptical tank

Skid Frame: Powder blue frame

Engine & Pump: 5,5 HP GX160 Honda engine
2" Banjo cast iron pump

Warranty: 1 year frame warranty
3 year non-prorated tank warranty

Spraying: Dust control nozzle
Hose bib kit
Plumbing recirculation kit

Size & weight: 96"(L) x 57" (W), Dry weight frame & tank - 800 lbs



Includes:

- 5.5 GX160 Honda engine and 2" Banjo cast iron pump
- Recirculation plumbing kit control proper volume of water flow to nozzle or the hose bibb.
- Dust control Nozzle-Stainless steel spray nozzle, adjustable from 8' wide to 35' and spray approximately 25' deep from the rear. The nozzle is perfect for arenas, tracks, mining roads, parking areas.
- Hose Bibb Kit - Pressure side, valve and 3/4" MGHT fitting

525 Gallon AquaDot Arena Water Trailer

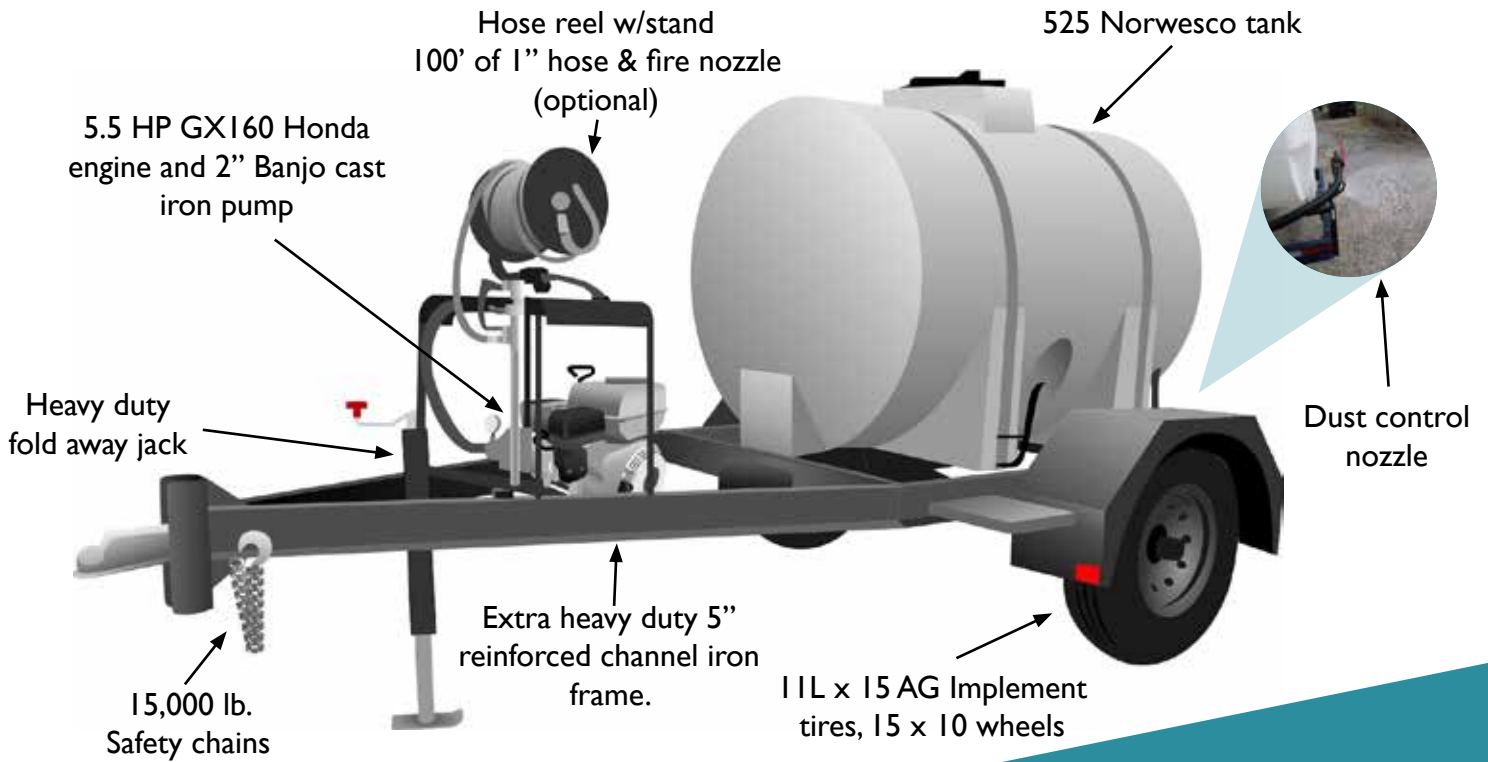

Features & Benefits

- Heavy duty frames
- Built-In rear spray bar
- Provides consistent footing



ONE
CLARION

SPECIFICATIONS

525 Gallon AquaDot Arena Water Trailer

Product Number: OC AquaDot-Arena Water Trailer 525 Gallon- AG-Non-DOT

Tank: 525 gal. Norwesco tank

Frame: Powder coated painted, extra heavy duty 5" channel iron frame, reinforced, back of frame extends 2" past end of tank to reduce accidental damage

Engine & pump: 5.5 HP GX160 Honda engine and 2" Banjo cast iron pump

Tires: Standard implement tires, 11L x 15 with 15 x 10 wheels

Tank Supports: 2" x 6" Rectangular tubing cross member tank supports

Jack: 15000 lbs safety chains, heavy duty fold away jack - folds away into the frame

Hitch: Choice of adjustable height hitch or standard clevis hitch

Warranty: 5 year frame warranty, 3 year non-prorated warranty on tank

Filling: 2" x 6" Rectangular tubing cross member tank supports

Suspension: 8000 Lbs slipper spring suspension

Spraying: Rear dust control nozzle

Size & weight: Dry weight trailer and tank-979 lbs, 148"(L) x 80"(H) x 84" (W)



Includes:

- 3 year non-prorated warranty on tank
- 5.5 HP GX160 Honda engine and 2" Banjo cast iron pump.
- Recirculation plumbing kit control proper volume of water flow to nozzle or hose bibb.
- Dust control nozzle -Stainless steel spray nozzle, adjustable from 8' wide to 35'. Spray approximately 25' deep from the rear.
- Hose bibb KIT - Pressure side, valve and 3/4" MGHT fitting-hose bibb connection to attach garden hose if needed.

1010 Gallon AquaDot Arena Water Trailer

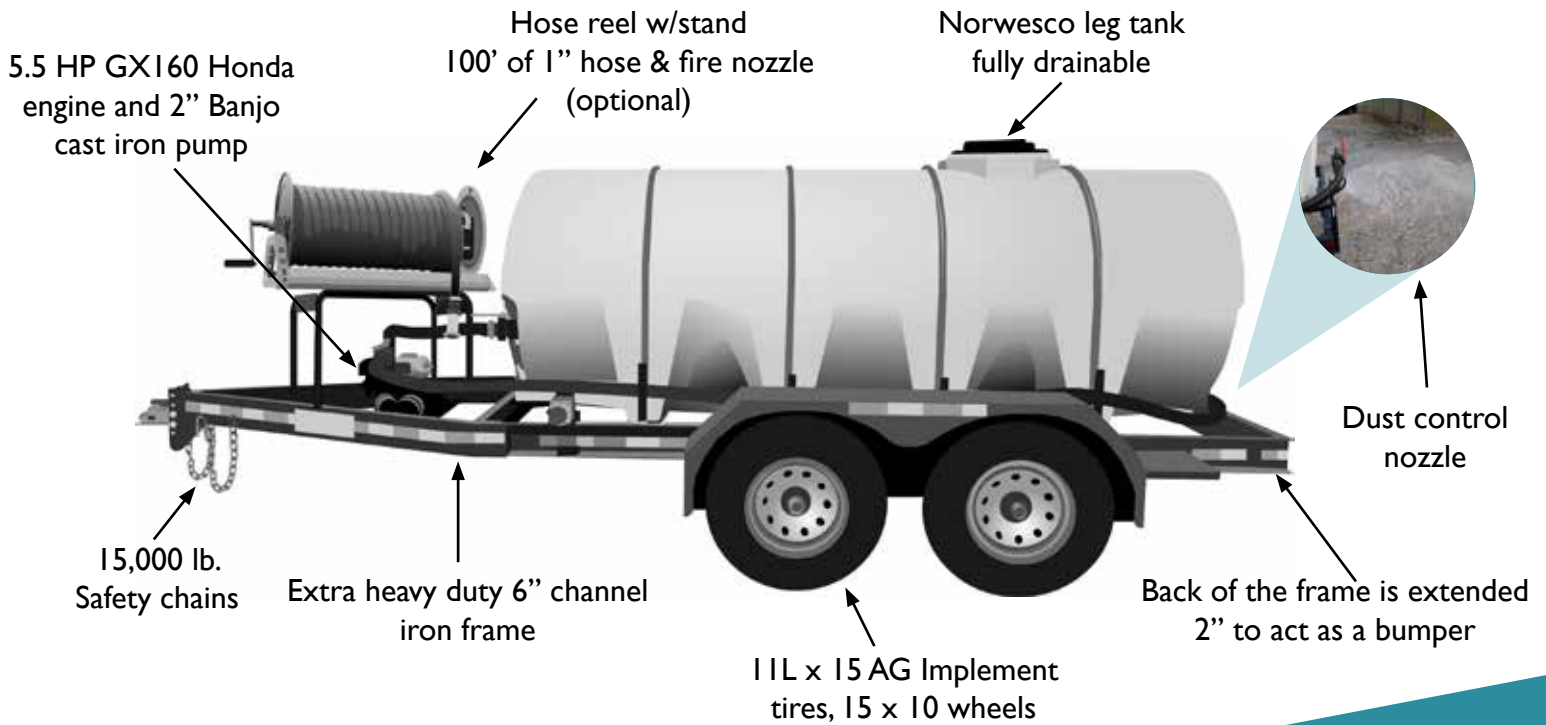

Features & Benefits

- Complete spray coverage
- Ready for immediate use
- Variety of sizes for multiple jobs



SPECIFICATIONS

1010 Gallon AquaDot Arena Water Trailer

Product Number: OC AquaDot-Arena Water Trailer 1010 Gallon: non-DOT

Tank: Norwesco leg tank fully drainable

Frame: Extra heavy duty 6" channel iron frame, powder coat paint, back of the frame is extended 2" to act as a bumper

Engine & pump: 5.5 HP GX160 Honda engine and 2" Banjo cast iron pump, mounting inside tongue for greater protection

Axle: Extra heavy duty cambered axles, tandem axle 16000 lbs

Tires: 11L x 15 AG Implement tires, 15 x 10 wheels

Tank supports: 2" x 6" rectangular tubing cross-member tank supports

Jack: Heavy duty jack that folds up inside the frame, 15000 lb. safety chains

Hitch: Choice of adjustable height hitch or standard clevis hitch

Warranty: 5 year frame warranty , 3 year non-prorated warranty on tank

Suspension: 8000 lb. slipper spring suspension

Spraying: Rear dust control nozzle

Size & weight: 221"(L) x 877"(H) x 87" (W), dry weight trailer and tank-1600 lbs



Includes:

- 5.5 HP GX160 Honda engine and 2" Banjo cast iron pump
- Recirculation plumbing kit control proper volume of water flow to nozzle or the hose bibb.
- Dust control nozzle -Stainless steel spray nozzle is adjustable from 8' wide to 35' spray approximately 25' deep from the rear. The nozzle is perfect for arenas, dog racing tracks, motorcross, parking areas.

1610 Gallon AquaDot Arena Water Trailer

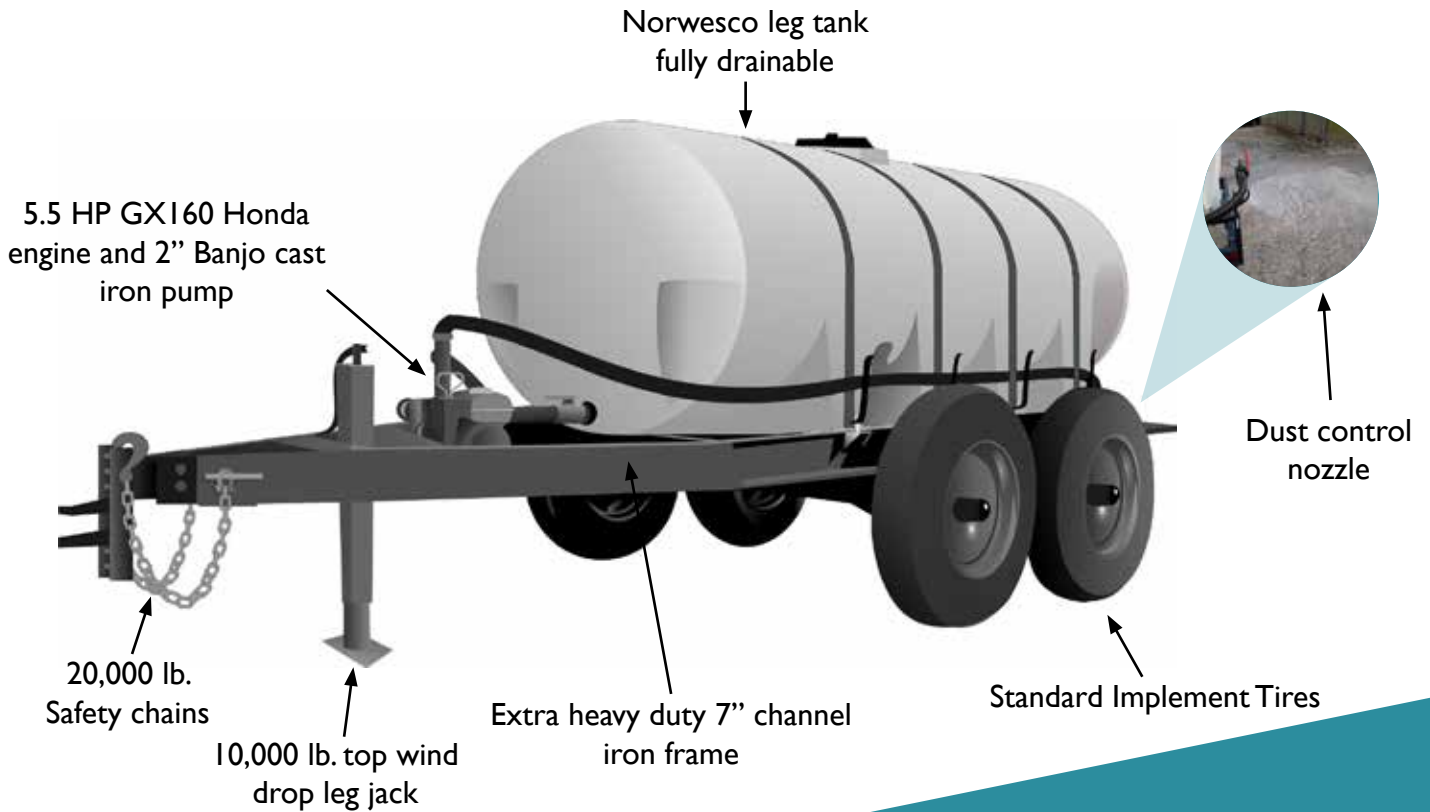

Includes:

- 5.5 HP GX160 Honda engine and 2" Banjo cast iron pump
- Recirculation plumbing kit to help control proper volume of water flow to dust control nozzle or hose bibb.
- Manual-rear dust control nozzle (No remote) -The powerful stainless steel spray nozzle is adjustable from 8' wide to 35' and spray approximately 25' deep from the rear. The nozzle is perfect for arenas, tracks, mining roads, parking areas.
- Hose bibb KIT - Pressure side, valve and 3/4" MGHT fitting - Hose bibb connection for customer to attach their own garden hose if needed.



ONE
CLARION

SPECIFICATIONS

1610 Gallon AquaDot Arena Water Trailer

Tank: Norwesco fully drainable tank

Frame: Extra heavy duty 7" channel iron frame, 5-year trailer frame warranty, Powder coat paint

Engine & Pump: 5.5 HP GX160 Honda engine and 2" Banjo cast iron pump

Axle: Slipper springs (tandem axle)

Tires: Standard implement tires 11L x 15 with 15 x 8" wheels 6-hole plugs

Tank Supports: Heavy duty cross member tank supports

Jack: 10,000 lb. top wind drop leg jack

Hitch: Choice of adjustable height hitch or standard clevis hitch

Warranty: 5 year frame warranty, 3 year non-prorated warranty on tank

Suspension: 5200 Lbs single torsion spring suspension

Spraying: Hose reel with stand

Size & Weight: 221"(L) x 77"(H) x 87" (W)

Features & Benefits

- Reliable watering for arenas
- Powerful pump with 3 year warranty
- Easy to tow around arena complex
- No additional equipment needed



What makes AquaDot trailers different?



We've got you covered

Very few (if any) of our competitors believe in their manufacturing process enough to offer a 5 year frame warranty and 1 year skid frame warranty. Our trailers are different; we take pride in providing the best product possible, delivered to your door. In addition to our manufacturer's frame warranty, we use only Norwesco tanks which provide a 3 year non-prorated tank warranty. Most all other tank manufacturers offer a prorated warranty, meaning if the tank is 75% through its warranty period that the warranty only covers 25% of the cost to replace the warranted tank. However, unlike the industry standard, **we use tanks with a non-prorated warranty.** What that means to you is that 100% of the tank is covered for the entire warranty period.

Stronger than the average

While commonly used for water hauling and spraying, our trailers are actually built to withstand use with heavier liquids. This gives you flexibility and peace of mind in knowing that your multi-purpose trailer can safely handle whatever you need. They are built to safely haul liquids such as water-based fertilizers (up to 11 lbs/gallon), whereas water weighs only 8.32 lbs/gallon. The frame also has high strength and active use with a manufacturing process that avoids cutting the channel iron wherever possible. Instead, the iron is bent and formed into shape, eliminating common weak points that are common with many other trailer frames. To add extra strength and ensure that there are no frame issues where the channel iron is bent, we reinforce it along the outside edge as well.

Things you don't see do matter

Have you ever purchased a trailer, only to find after a few months that rust is already showing? This results from a manufacturer that's more concerned with speed than with quality. You won't find that with AquaDot trailers. Our trailers get a good scrubbing before the powder coat paint finish is applied. Attention to even little details like this help ensure a long life for your trailer and are important to us.

Freight savings, shorter lead times, delivered fully assembled

Select the shipping location that best fits your needs for freight and lead time. We ship from AL, AZ, CA, KS, KY, MN, ND, NE, WA. There's no need to wait for lead times of today's world - we always keep a supply of the AquaDot trailers in production.

For more complete information on One Clarion products and solutions, visit us on the web at: www.clarionmunicipal.com or call us at : (+1) 863-261-8388 | info@oneclarion.com

© 2023 One Clarion. All rights reserved. One Clarion terms and conditions apply.



500 gallon Arena Water Wagon

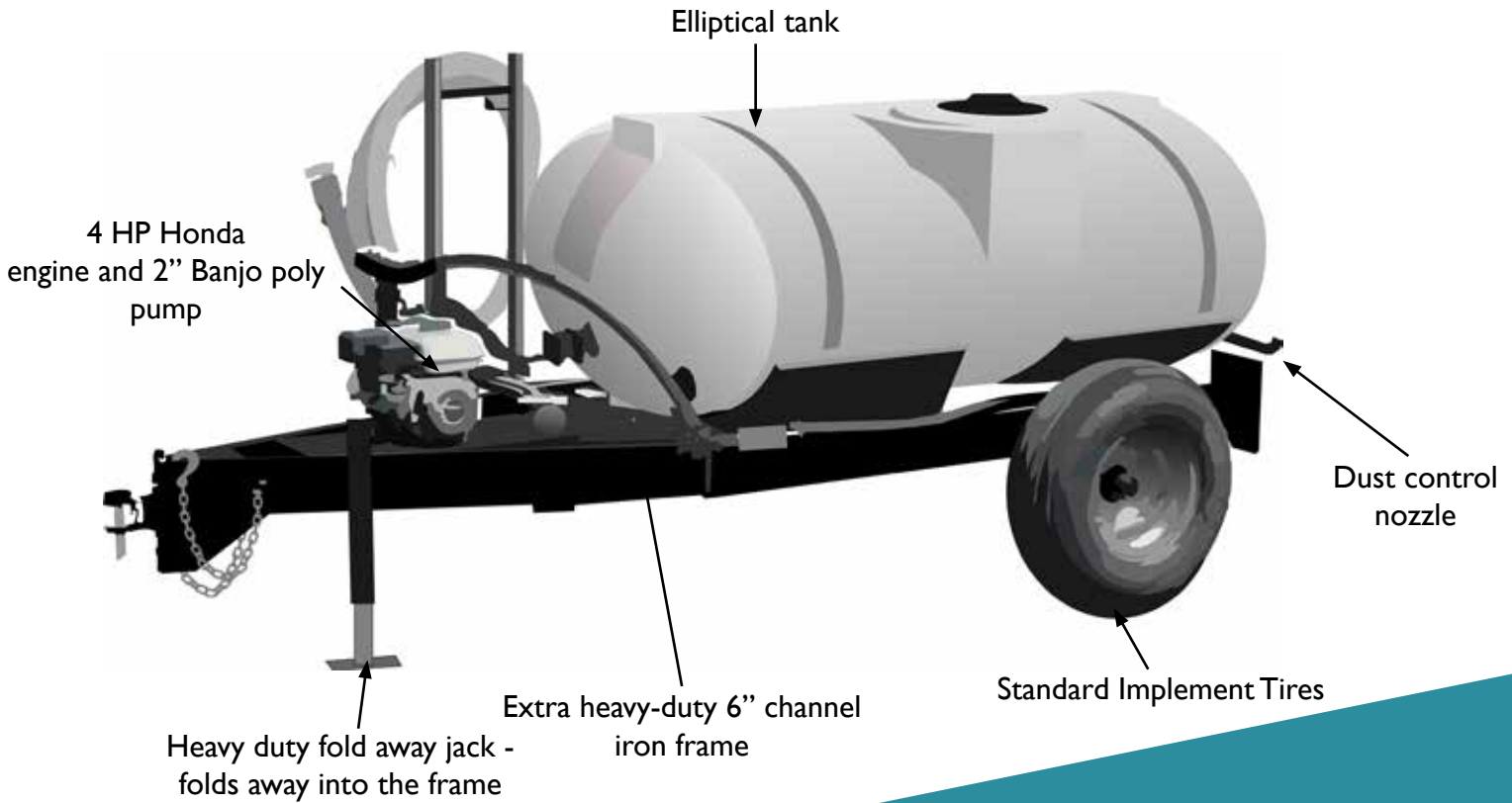

Includes:

- 1-year Warranty on elliptical tank
- 4 HP Honda engine and 2" Banjo poly pump
- 25' of 1.5" Hose with fire nozzle for greater accessibility
- 2" x 20' Suction fill hose with screen giving flexible filling options
- Galvanized rear spray bar providing wide spraying coverage
- 1.5" Ratchet on/off ball valve



SPECIFICATIONS

500 gallon Arena Water Wagon

Part# AD-ADC-0500-W

Tank: 500 gallon tank

Frame: Extra heavy duty 6" channel iron frame, black acrylic paint on frame

Engine & Pump: 4 HP Honda engine and 2" Banjo poly pump

Axle: Slipper springs (tandem axle)

Tires: Standard implement tires 11L x 15 with 15 x 8" wheels 6-hole plugs

Tank Supports: Heavy duty cross member tank supports

Jack: Heavy duty fold away jack - folds away into the frame

Hitch: Adjustable height clevis hitch

Warranty: 1-Year frame warranty, 1-year warranty on elliptical tank

Suspension: 5200 lbs Single torsion spring suspension

Spraying: 25' of 1.5" Hose with fire nozzle, galvanized rear spray bar

Size & Weight: 148"(L) x 64"(H) x 78" (W), Dry weight trailer and tank-850 lbs

Features & Benefits

- Reliable Honda engine and Banjo pump
- Heavy duty frame
- Great maneuverability
- Durable, reliable frame and tank
- Ready to use
- Wide coverage area



1025 gallon Arena Water Wagon

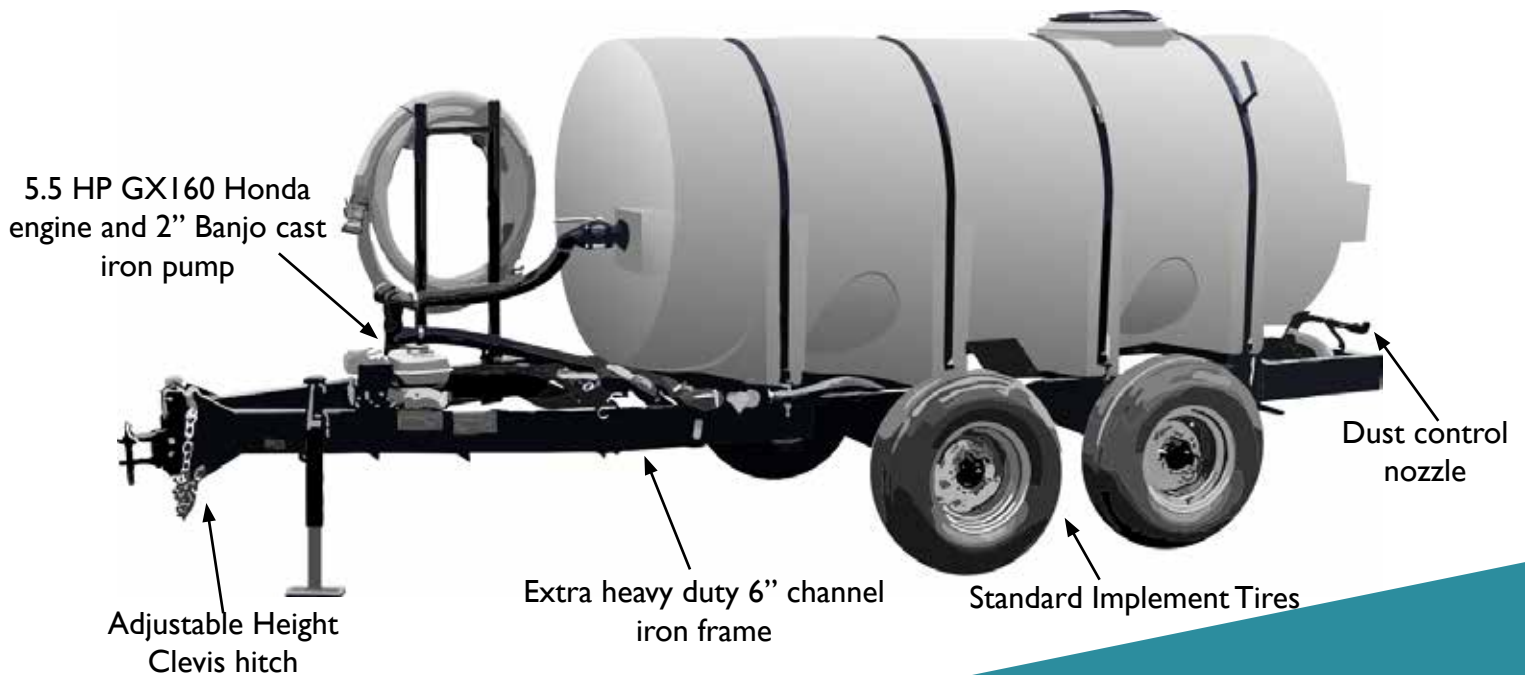

Includes:

- 1-year Warranty on tank
- 4 HP Honda engine and 2" Banjo poly pump
- 25' of 1.5" hose with fire nozzle for spot spraying and targeted areas
- 2" x 20' Suction fill hose with screen
- Galvanized rear spray bar
- 1.5' Ratchet on/off ball valve for quick hauling capabilities
- Dual tandem axle for greater stability and maneuvering.



SPECIFICATIONS

1025 gallon Arena Water Wagon

Part# AD-ADC-1025-W

Tank: 1025 gallon tank

Frame: Extra heavy-duty 6" channel iron frame, powder coat paint

Engine & Pump: 4 HP Honda engine and 2" Banjo poly pump

Axle: 14,000 Lbs Tandem axle

Tires: Standard Implement tires 11L x 15 with 15 x 8" wheels 6-hole plugs

Tank Supports: Heavy duty cross member tank supports

Jack: Heavy duty fold away jack - folds away into the frame

Hitch: Adjustable height clevis hitch

Warranty: 1 year frame and tank warranty,

Spraying: 25' of 1.5" Hose with fire nozzle, galvanized rear spray bar

Size & Weight: 200"(L) x 82"(H) x 80" (W), Dry weight trailer and tank-1800 lbs

Features & Benefits

- Tandem axle for added stability
- Wide spray range
- Suction hose for flexible filling
- A variety of uses for farm and off-road use



Additional Water Trailer and Skid Options

300, 525, 1010, and 1610 Gallon AquaDot Arena Water trailer	500 Gallon Elliptical AquaDot Dust Control Skid	500 and 1025 Gallon Arena Water Wagon
<p>2" PVC Suction hose 20' kit with strainer- with or without stand</p> <p>12 Volt remote control sprayer on/off functionality.</p> <p>Hose reel w/stand, 100' of 1" hose & fire nozzle spray approximately 50-60 feet horizontal jet. 15-20 feet vertical</p> <p>2" or 2 5/16" Ball coupler hitch</p> <p>DOT Package: Electric brakes, fenders, LED lighting, reflector, 10 ply highway rated tires</p>	<p>2" PVC Suction hose 20' kit with strainer- with or without stand</p> <p>12 Volt remote control sprayer on/off functionality</p> <p>1" Manual rewind hose reel</p> <p>50' of 1" EPDM Hose</p>	<p>12 Volt bluetooth on/off valve for spray bar</p> <p>12 Volt bluetooth on/off valve with hand remote kit.</p> <p>50' of 1" Mounted hose hand crank reel, 180° swivel with fire nozzle</p> <p>Fire hydrant and pond fill kit</p> <p>Side water spray kit- up to 15' swath</p> <p>Anti siphon fill kit, 500-gal trailer only</p> <p>100' of 1" red hose with fire nozzle</p>



For more complete information on One Clarion products and solutions, visit us on the web at: www.clarionmunicipal.com or call us at : (+1) 863-261-8388 | info@oneclarion.com

© 2023 One Clarion. All rights reserved. One Clarion terms and conditions apply.

