

16 inch lid

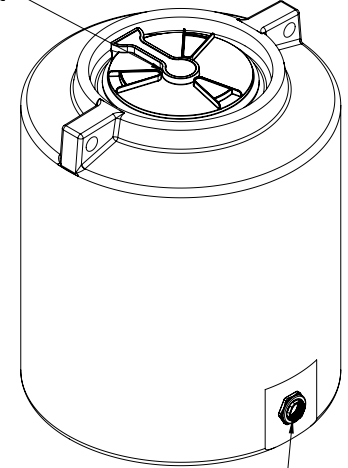

2 inch threaded fitting

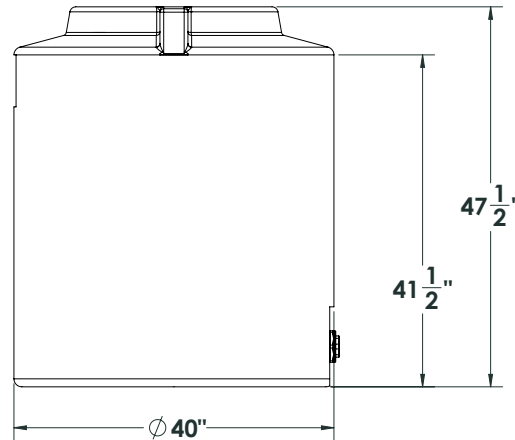
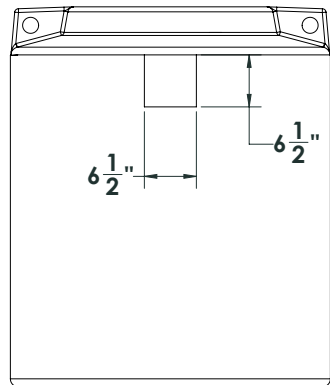

NOTE: Allow +/- 1.5% Shrinkage

PROPRIETARY AND CONFIDENTIAL
 THE INFORMATION CONTAINED IN THIS DRAWING IS THE SOLE PROPERTY OF ENDURAPLAS LLC. ANY REPRODUCTION IN PART OR AS A WHOLE WITHOUT THE WRITTEN PERMISSION OF ENDURAPLAS LLC IS PROHIBITED.

		UNLESS OTHERWISE SPECIFIED:	DRAWN	NAME	DATE	ENDURAPLAS LLC
		DIMENSIONS ARE IN INCHES	DNS		10/31/16	
		FRACTIONAL: ±	CHECKED			THV00210
		ANGULAR: MACH ± BEND ±	ENG APPR.			
		TWO PLACE DECIMAL: ±	MFG APPR.			C
		THREE PLACE DECIMAL: ±	Q.A.			1
		INTERPRET GEOMETRIC TOLERANCING PER:	COMMENTS:			SCALE: 1:16 WEIGHT:
		MATERIAL				SHEET 1 OF 1
		FINISH				
NEXT ASSY	USED ON	APPLICATION	DO NOT SCALE DRAWING			

For more information or to get your questions answered, contact us!
www.clarionmunicipal.com or call us at : (+1) 863-261-8388 | info@oneclarion.com