

4

3

2

1

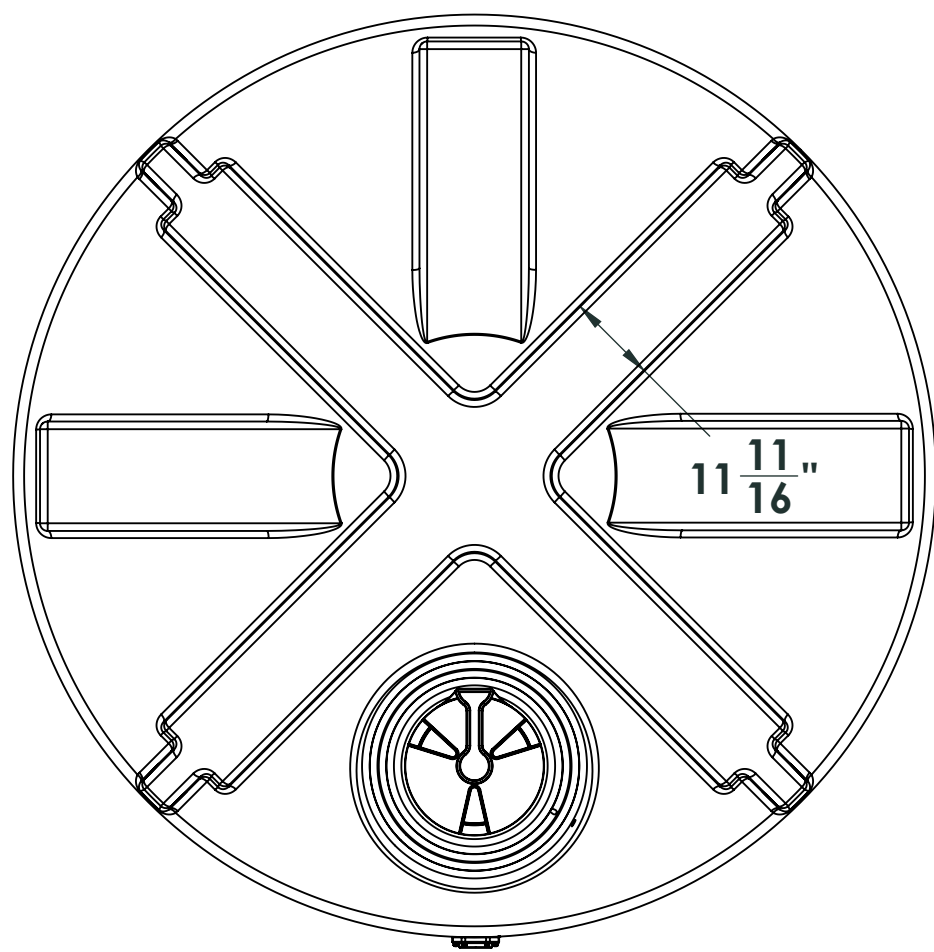

16 inch lid

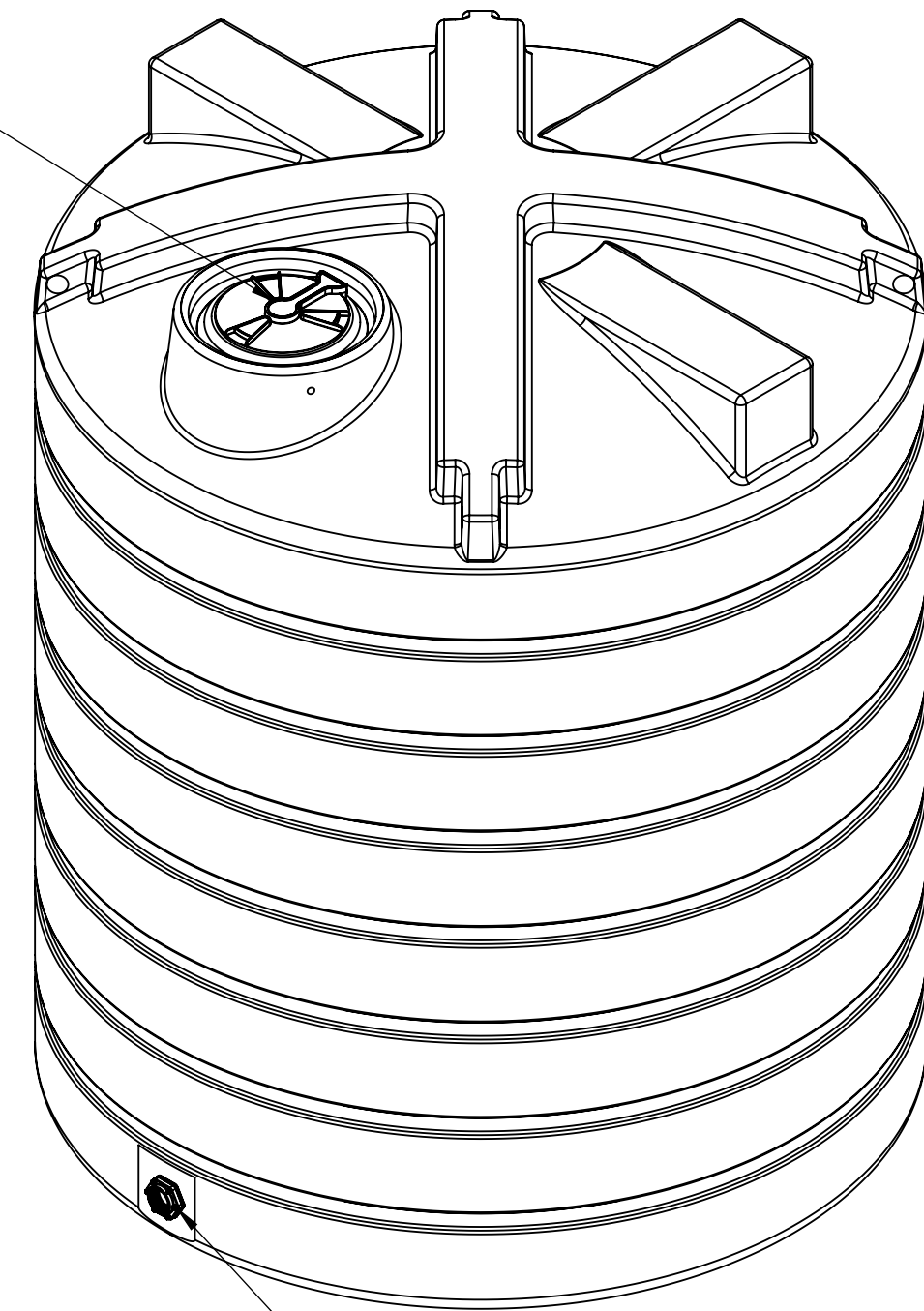

3 inch bolted fitting

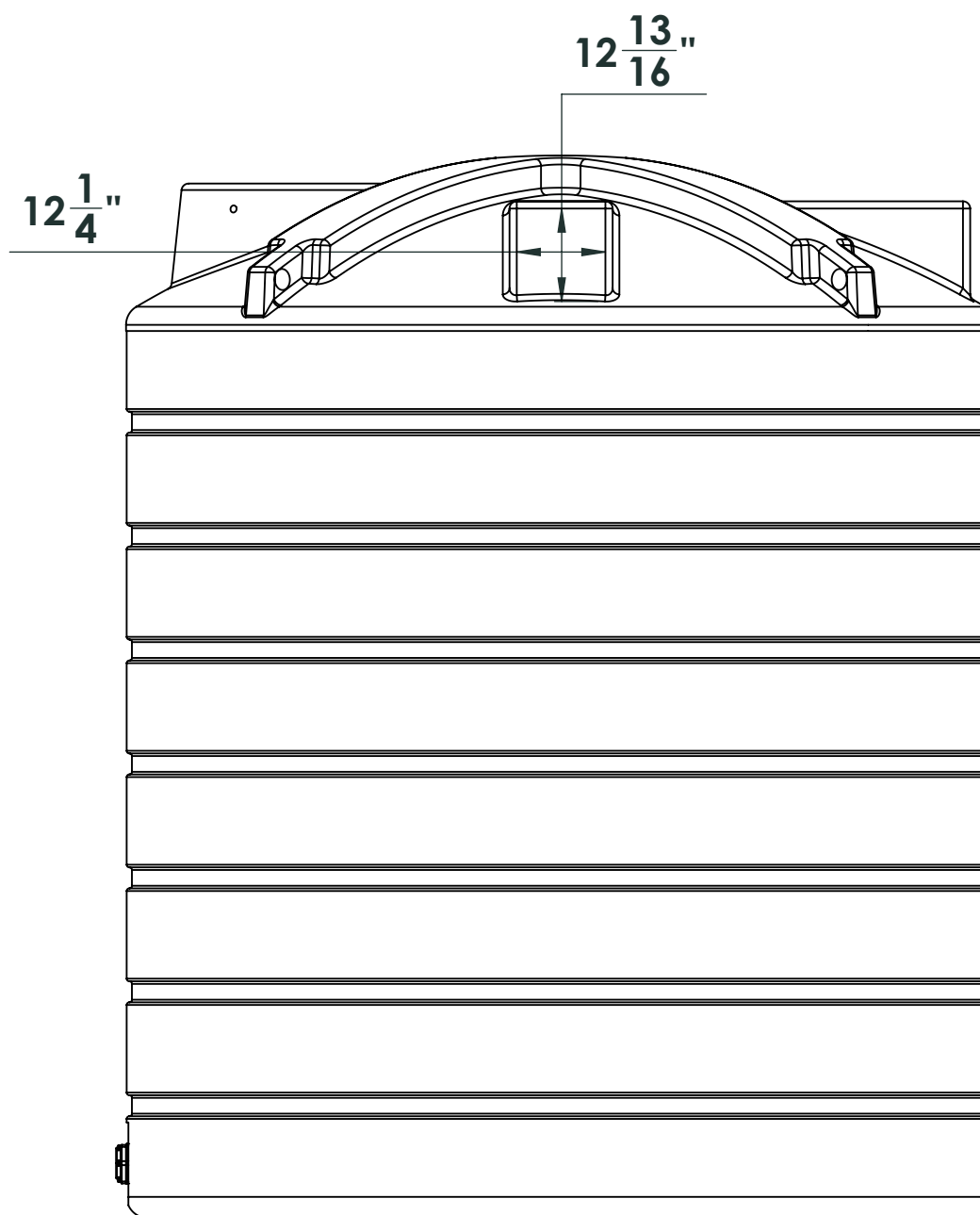
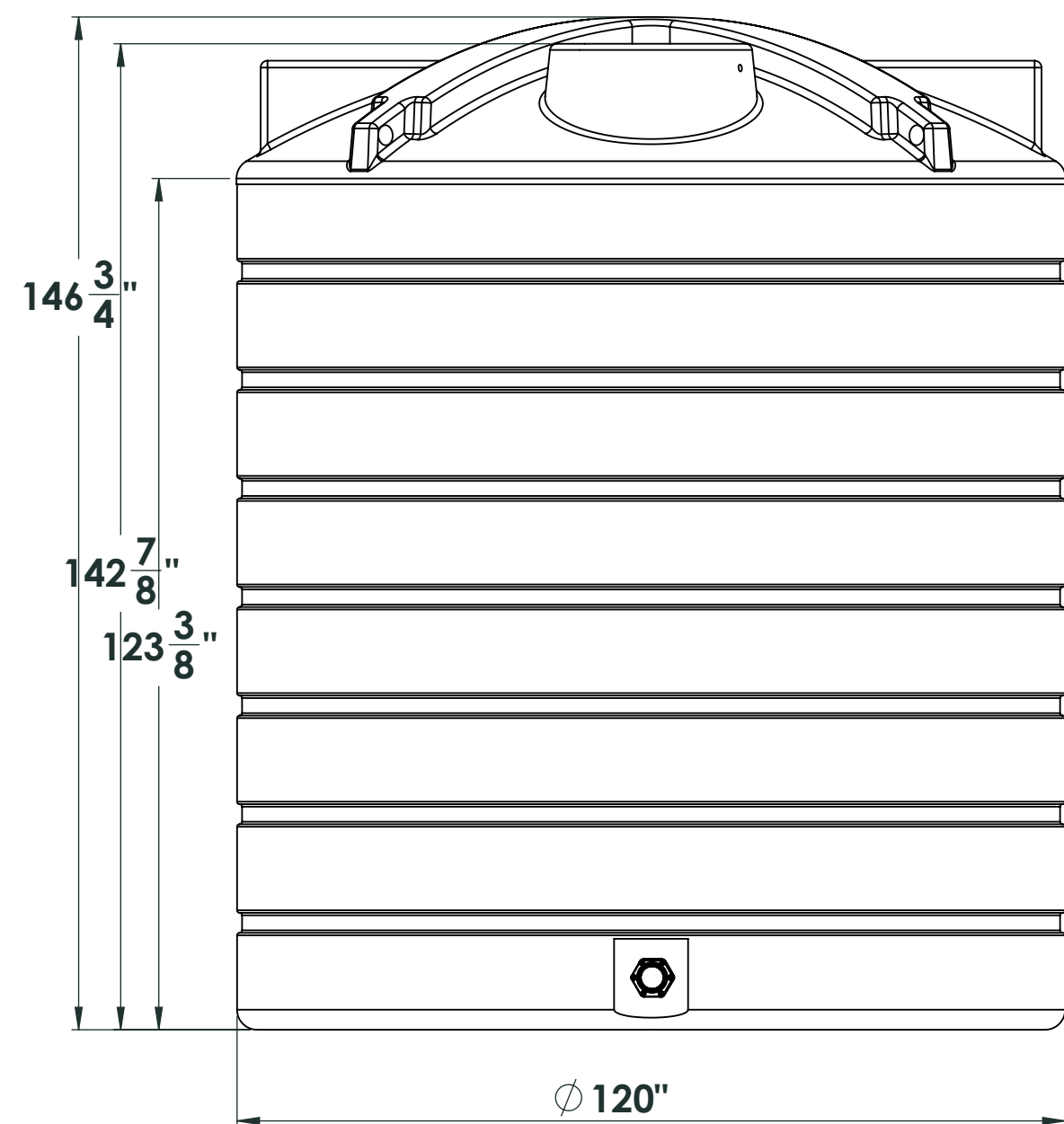

NOTE: Allow +/- 1.5% Shrinkage

For more information or to get your questions answered, contact us!
www.clarionmunicipal.com or call us at : (+1) 863-261-8388 | info@oneclarion.com

PROPRIETARY AND CONFIDENTIAL
THE INFORMATION CONTAINED IN THIS DRAWING IS THE SOLE PROPERTY OF ENDURAPLAS LLC. ANY REPRODUCTION IN PART OR AS A WHOLE WITHOUT THE WRITTEN PERMISSION OF ENDURAPLAS LLC IS PROHIBITED.

UNLESS OTHERWISE SPECIFIED:		NAME	DATE	ENDURAPLAS LLC
DIMENSIONS ARE IN INCHES		DRAWN	DNS	
TOLERANCES:		CHECKED		TITLE:
FRACTIONAL ±		ENG APPR.		THV06250
ANGULAR: MACH ± BEND ±		MFG APPR.		
TWO PLACE DECIMAL ±		Q.A.		SIZE DWG. NO.
THREE PLACE DECIMAL ±		COMMENTS:		REV
INTERPRET GEOMETRIC TOLERANCING PER:				1
MATERIAL				SCALE: 1:50 WEIGHT:
FINISH				SHEET 1 OF 1
NEXT ASSY	USED ON			
APPLICATION				
DO NOT SCALE DRAWING				

4

3

2

1