

4

3

2

1

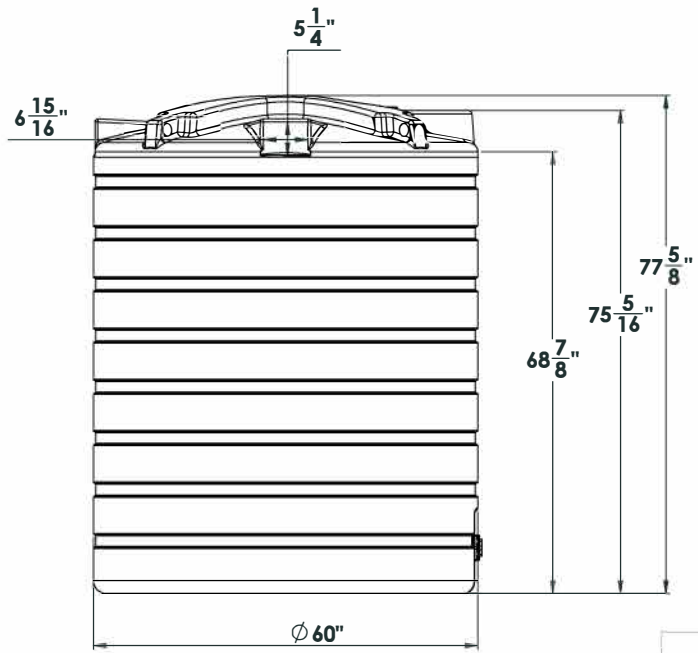
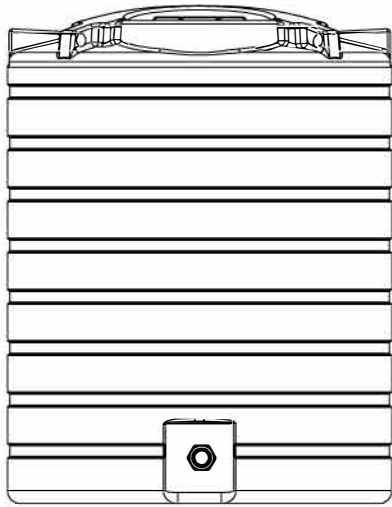
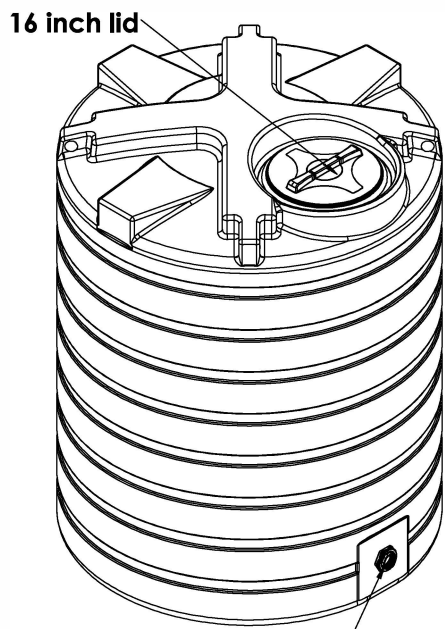
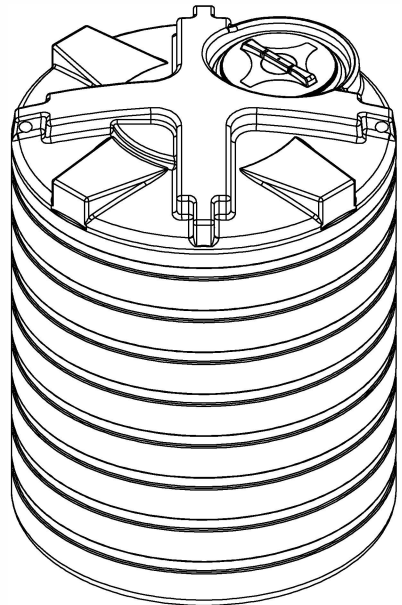
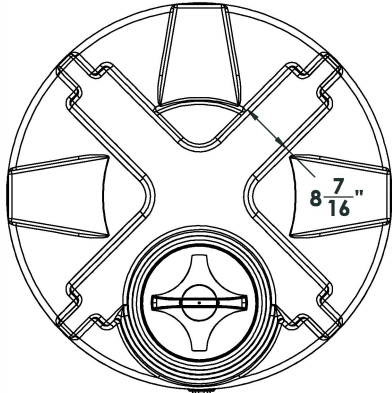

**NOTE: Allow +/- 1.5% Shrinkage**

For more information or to get your questions answered, contact us!  
[www.clarionmunicipal.com](http://www.clarionmunicipal.com) or call us at : (+1) 863-261-8388 | [info@oneclarion.com](mailto:info@oneclarion.com)

**PROPRIETARY AND CONFIDENTIAL**  
 THE INFORMATION CONTAINED IN THIS DRAWING IS THE SOLE PROPERTY OF ENDURAPLAS LLC. ANY REPRODUCTION IN PART OR AS A WHOLE WITHOUT THE WRITTEN PERMISSION OF ENDURAPLAS LLC IS PROHIBITED.

UNLESS OTHERWISE SPECIFIED:		DRAWN	NAME	DATE	<b>ENDURAPLAS LLC</b>	
DIMENSIONS ARE IN INCHES		CHECKED	DNS	10/31/16	TITLE:	
TOLERANCES:		ENG APPR.			<b>TLV00870</b>	
FRACTIONAL ±		MFG APPR.			SIZE DWG. NO.	
ANGULAR: MACH ±		Q.A.			<b>C</b>	
BEND ±		COMMENTS:			REV	
TWO PLACE DECIMAL ±					<b>1</b>	
THREE PLACE DECIMAL ±					SCALE: 1:20 WEIGHT: SHEET 1 OF 1	
INTERPRET GEOMETRIC TOLERANCING PER:						
MATERIAL:						
FINISH:						
NEXT ASSY	U SEB/N					
APPLICATION		DO NOT SCALE DRAWING				

4

3

2

1