

4

3

2

1

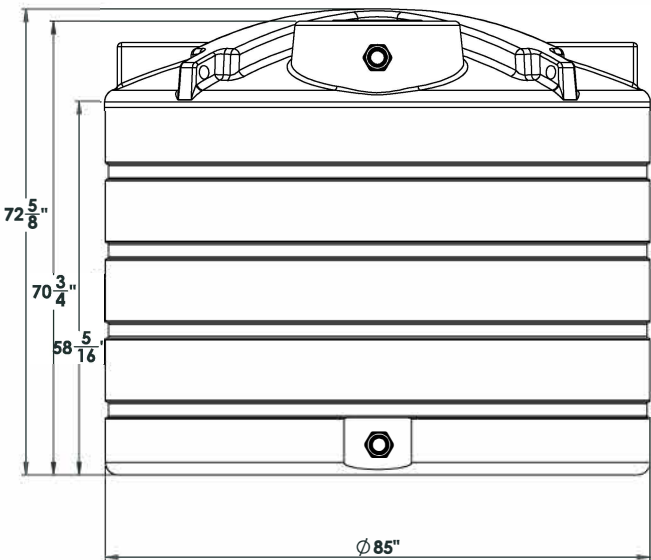
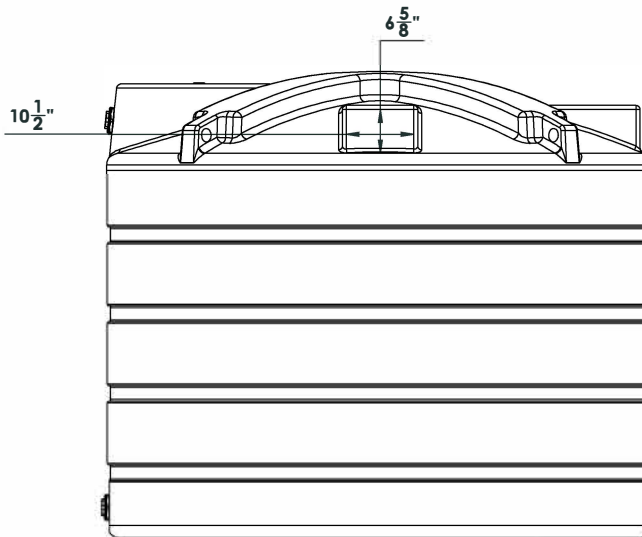
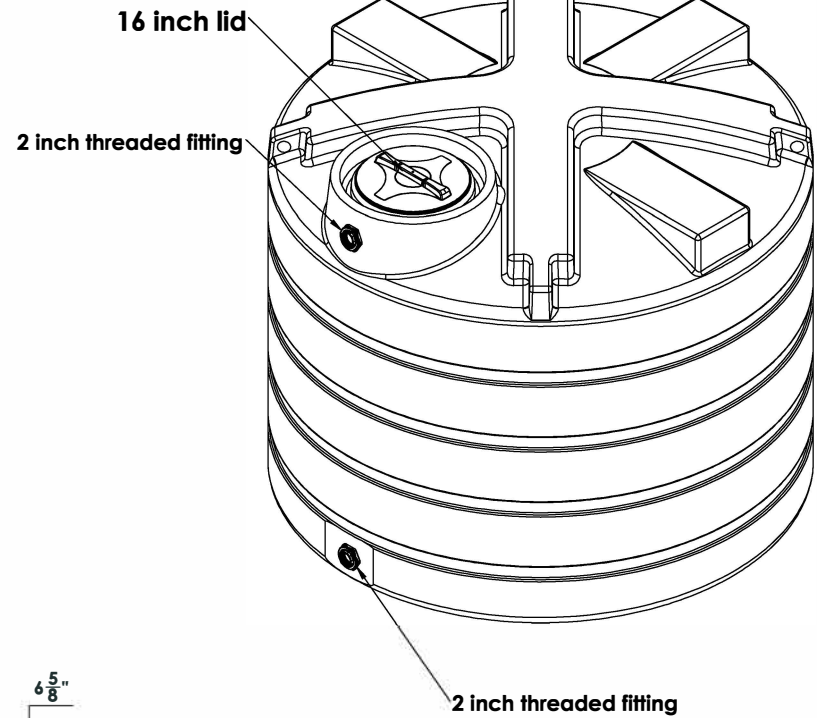
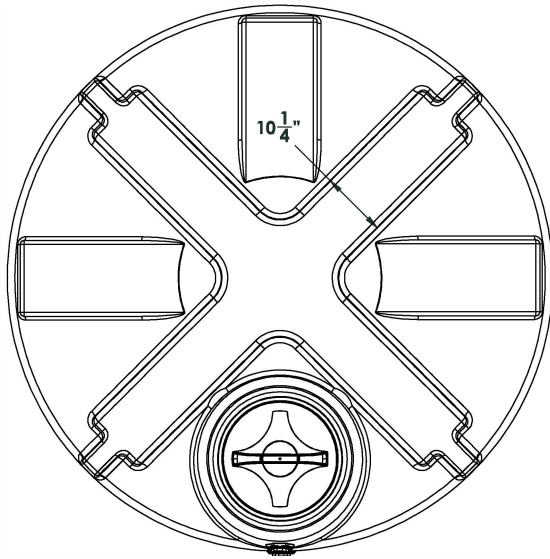

NOTE: Allow +/- 1.5% Shrinkage

For more information or to get your questions answered, contact us!
www.clarionmunicipal.com or call us at : (+1) 863-261-8388 | info@oneclarion.com

PROPRIETARY AND CONFIDENTIAL
 THE INFORMATION CONTAINED IN THIS DRAWING IS THE SOLE PROPERTY OF ENDURAPLAS LLC. ANY REPRODUCTION IN PART OR AS A WHOLE WITHOUT THE WRITTEN PERMISSION OF ENDURAPLAS LLC IS PROHIBITED.

UNLESS OTHERWISE SPECIFIED:		DRAWN	NAME	DATE	ENDURAPLAS LLC	
DIMENSIONS ARE IN INCHES		CHECKED	DNS	10/31/16	TITLE:	
TOLERANCES:		ENG APPR.			TLV01350	
FRACTIONAL ±		MFG APPR.			SIZE DWG. NO.	
ANGULAR MATCH BEND ±		Q.A.			C	
TWO PLACE DECIMAL ±		COMMENTS:			REV	
THREE PLACE DECIMAL ±					1	
INTERPRET GEOMETRIC TOLERANCING PER:					SCALE: 1:50 WEIGHT:	
MATERIAL:					SHEET 1 OF 1	
FINISH:						
NEXT ASSY	US EDN	APPLICATION	DO NOT SCALE DRAWING			

4

3

2

1