



# Dust Suppression

## Bust The Dust

### Dust Suppression Trailers

Rugged, high-capacity dust suppression trailer controls dust on construction sites, roadways, and your property. The spray bar lets you easily water down the grounds, parking lots and roads, keeping dust to a minimum. Ready to use for all your dust abatement needs.

These models are for on grounds use, but DOT packages are also available. Just ask us!

## Wide-Range Dust Control

Outfitted with the features you really need, our dust sprayer trailer gives you consistent water distribution for your site. Use for dust control, roadbed compaction, and watering remote landscape. Ideal for:

- Construction sites
- Arena packing
- Dust control
- Jobsite ground packing
- Parking lots
- Race tracks
- Landscaping
- Mining



# 300 Gallon AquaDot Dust Suppression

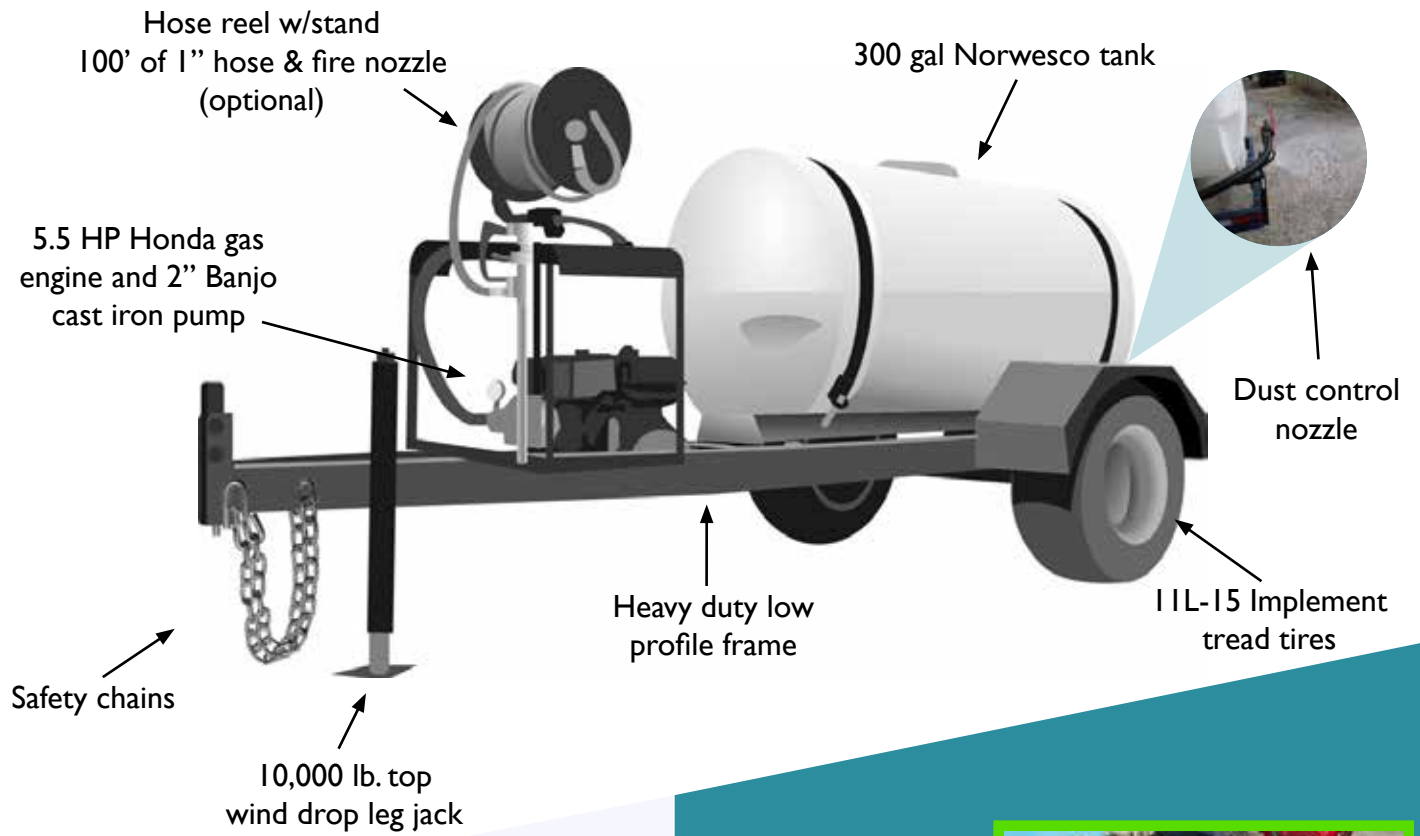

## Features & Benefits

- Easy transportation for farms, construction sites, and jobsites
- Great maneuverability for on and off-road use
- Quickly control dust in a variety of applications



**ONE**  
CLARION

## SPECIFICATIONS

### 300 Gallon AquaDot Dust Suppression Trailer

Product Number: OC AquaDot-Dust Suppression Trailer 300 Gallon -Non DOT

Tank: 300 gal Norwesco tank

Frame: Heavy duty low profile, Powder coated painted

Engine & pump: 5.5 HP Honda gas engine, 2" Banjo cast iron pump

Tires: 11L-15 Implement tread tires

Jack: 15" Jack

Safety chains

Hitch: Choice of adjustable height hitch or standard clevis hitch

Warranty: 5 year frame warranty, 3 year non-prorated warranty on tank

Spraying: Rear dust control nozzle

Size & Weight: 126"(L) x 54"(H) x 83" (W), Dry weight and tank- 900 lbs



#### Includes:

- 3-year non-prorated warranty tank
- 5.5 HP GX160 Honda engine and 2" Banjo cast iron pump
- Recirculation plumbing kit control the proper volume of water flow to nozzle or hose bibb.
- Dust control nozzle -Stainless steel spray nozzle is adjustable from 8' wide to 35' . Spray approximately 25' deep from the rear.
- Hose bibb KIT - Pressure side, valve and 3/4" MGHT fitting - Hose bibb connection to attach garden hose if needed.

# 500 Gallon Elliptical AquaDot Dust Control Skid

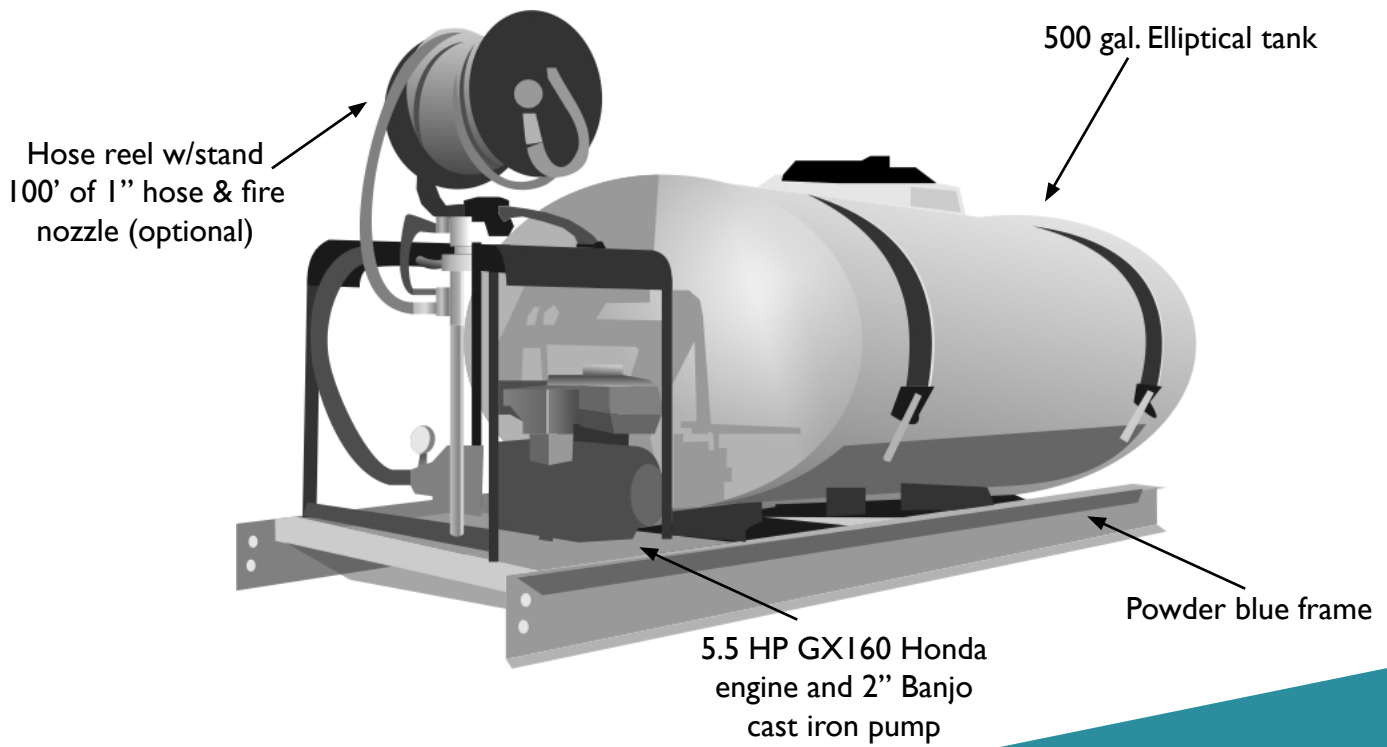

## Consistent, Reliable Control

Maintain dust control on roads, jobsites, arenas and parking lots. Our versatile skid sprayers can easily be loaded in UTVs, ATVs, trailers or pickup trucks to use on construction sites, remote jobs, and farms.



**ONE**  
CLARION

# SPECIFICATIONS

## 500 Gallon Elliptical AquaDot Dust Control Skid

Product Number: OC AquaDot Elliptical Dust Suppression Skid 500 Gallon

Tank: 500 gal. Elliptical tank

Skid Frame: Powder blue frame

Engine & Pump: 5,5 HP GX160 Honda engine  
2" Banjo cast iron pump

Warranty: 1 year frame warranty  
3 year non-prorated tank warranty

Spraying: Dust control nozzle  
Hose bib kit  
Plumbing recirculation kit

Size & weight: 96"(L) x 57" (W), Dry weight frame & tank - 800 lbs



### Includes:

- 5.5 GX160 Honda engine and 2" Banjo cast iron pump
- Recirculation plumbing kit control proper volume of water flow to nozzle or the hose bibb.
- Dust control Nozzle-Stainless steel spray nozzle, adjustable from 8' wide to 35' and spray approximately 25' deep from the rear. The nozzle is perfect for arenas, tracks, mining roads, parking areas.
- Hose Bibb Kit - Pressure side, valve and 3/4" MGHT fitting

# 525 Gallon AquaDot Dust Suppression Trailer

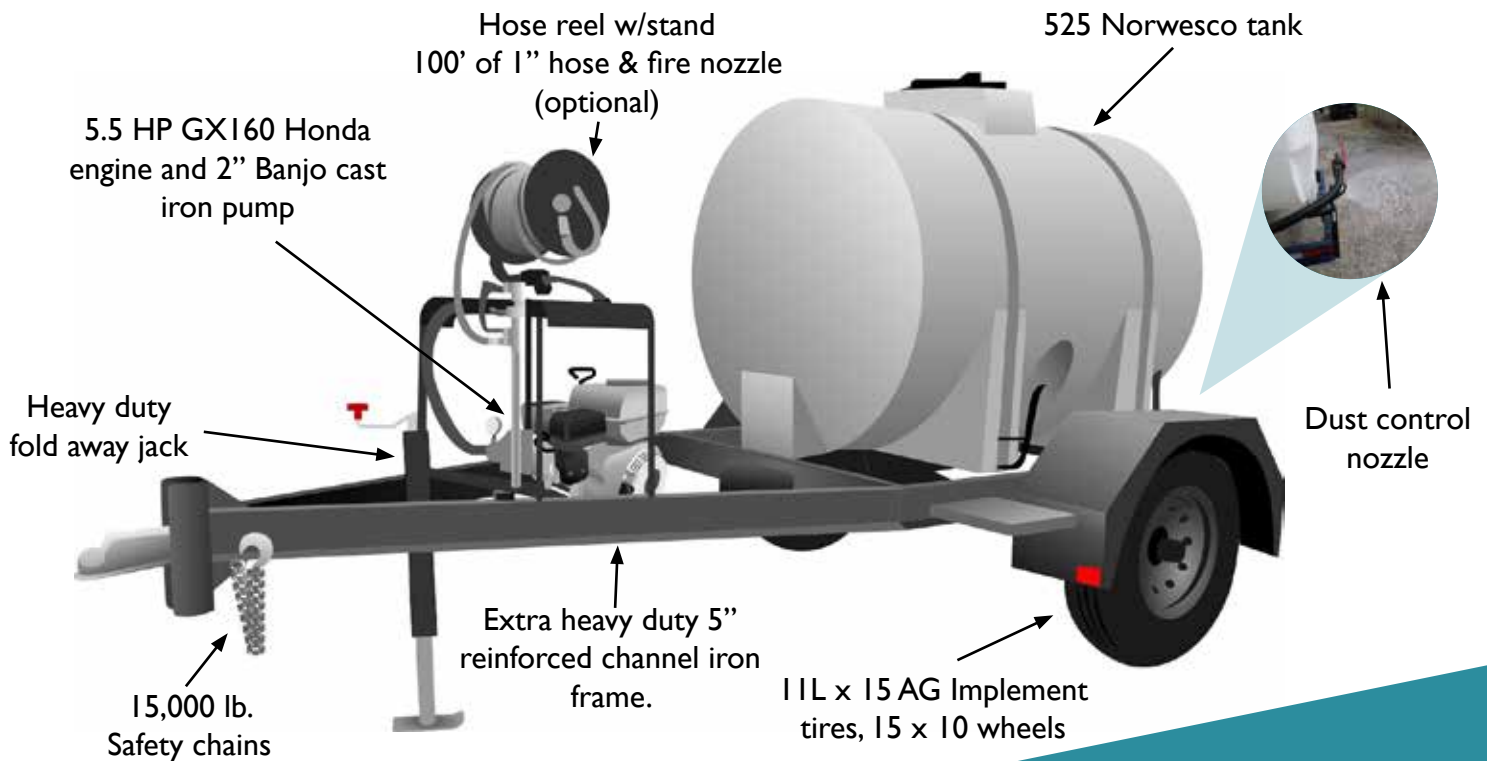

## Features & Benefits

- Heavy duty frames
- Built-In rear spray bar
- Provides consistent dust abatement
- Additional options available



**ONE**  
CLARION

# SPECIFICATIONS

## 525 Gallon AquaDot Dust Suppression Trailer

Product Number: OC AquaDot-Dust Suppression Trailer 525 Gallon- AG-Non-DOT

Tank: 525 gal. Norwesco tank

Frame: Powder coated painted, extra heavy duty 5" channel iron frame, reinforced, back of frame extends 2" past end of tank to reduce accidental damage

Engine & pump: 5.5 HP GX160 Honda engine and 2" Banjo cast iron pump

Tires: Standard implement tires, 11L x 15 with 15 x 10 wheels

Tank Supports: 2" x 6" Rectangular tubing cross member tank supports

Jack: 15000 lbs safety chains, heavy duty fold away jack - folds away into the frame

Hitch: Choice of adjustable height hitch or standard clevis hitch

Warranty: 5 year frame warranty, 3 year non-prorated warranty on tank

Filling: 2" x 6" Rectangular tubing cross member tank supports

Suspension: 8000 Lbs slipper spring suspension

Spraying: Rear dust control nozzle

Size & weight: Dry weight trailer and tank-979 lbs, 148"(L) x 80"(H) x 84" (W)



### Includes:

- 3 year non-prorated warranty on tank
- 5.5 HP GX160 Honda engine and 2" Banjo cast iron pump.
- Recirculation plumbing kit control proper volume of water flow to nozzle or hose bibb.
- Dust control nozzle -Stainless steel spray nozzle, adjustable from 8' wide to 35'. Spray approximately 25' deep from the rear.
- Hose bibb kit - Pressure side, valve and 3/4" MGHT fitting-hose bibb connection to attach garden hose if needed.

# 1010 Gallon AquaDot Dust Suppression Trailer

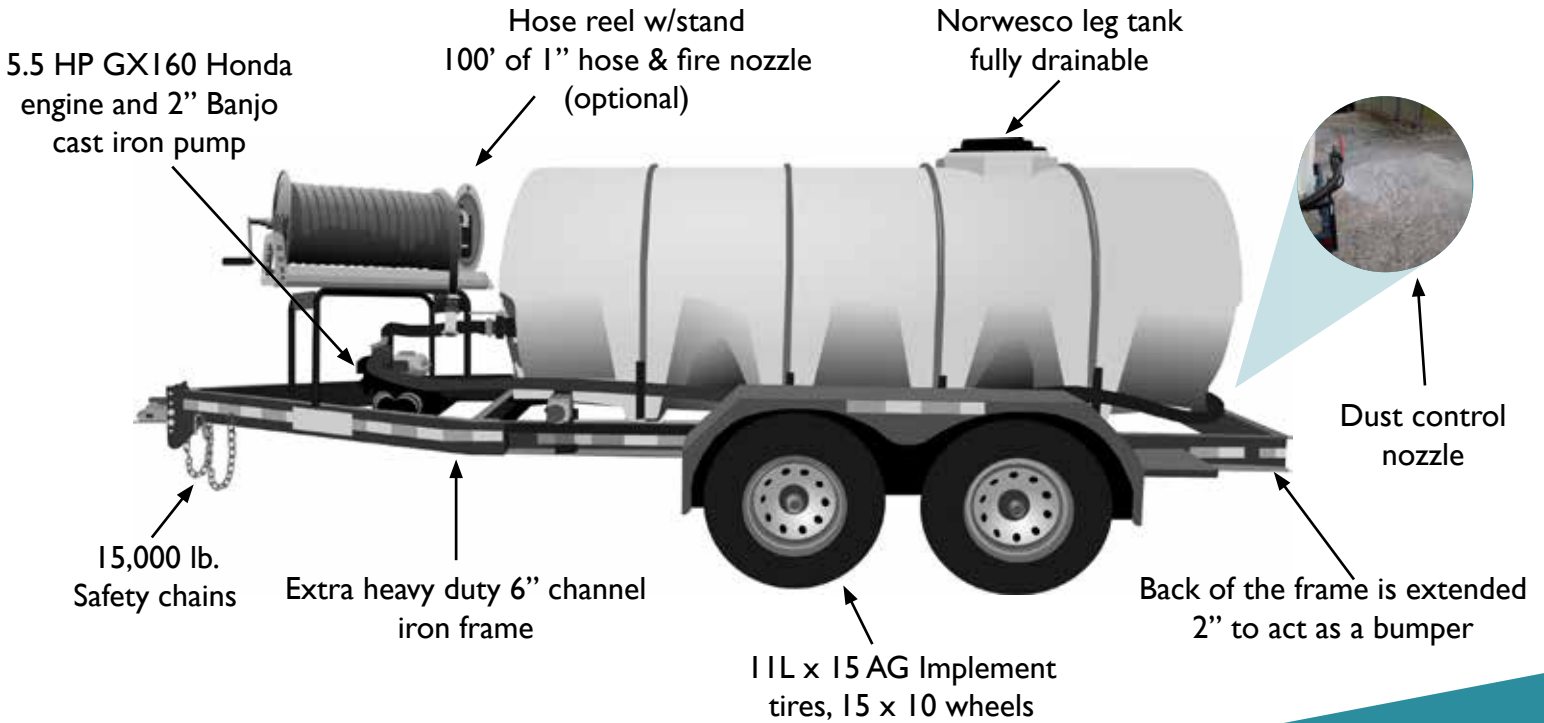

## Features & Benefits

- Complete spray coverage
- Ready for immediate use
- Variety of sizes available for multiple jobs





## SPECIFICATIONS

### 1010 Gallon AquaDot Dust Suppression Trailer

Product Number: OC AquaDot-Dust Suppression Trailer 1010 Gallon: non-DOT

Tank: Norwesco leg tank fully drainable

Frame: Extra heavy duty 6" channel iron frame, powder coat paint, back of the frame is extended 2" to act as a bumper

Engine & pump: 5.5 HP GX160 Honda engine and 2" Banjo cast iron pump, mounting inside tongue for greater protection

Axle: Extra heavy duty cambered axles, tandem axle 16000 lbs

Tires: 11L x 15 AG Implement tires, 15 x 10 wheels

Tank supports: 2" x 6" rectangular tubing cross-member tank supports

Jack: Heavy duty jack that folds up inside the frame, 15000 lb. safety chains

Hitch: Choice of adjustable height hitch or standard clevis hitch

Warranty: 5 year frame warranty , 3 year non-prorated warranty on tank

Suspension: 8000 lb. slipper spring suspension

Spraying: Rear dust control nozzle

Size & weight: 221"(L) x 877"(H) x 87" (W), dry weight trailer and tank-1600 lbs



#### Includes:

- 5.5 HP GX160 Honda engine and 2" Banjo cast iron pump
- Recirculation plumbing kit control proper volume of water flow to nozzle or the hose bibb.
- Dust control nozzle -Stainless steel spray nozzle is adjustable from 8' wide to 35' spray approximately 25' deep from the rear. The nozzle is perfect for arenas, dog racing tracks, motorcross, parking areas.

# 1610 Gallon AquaDot Dust Suppression Trailer

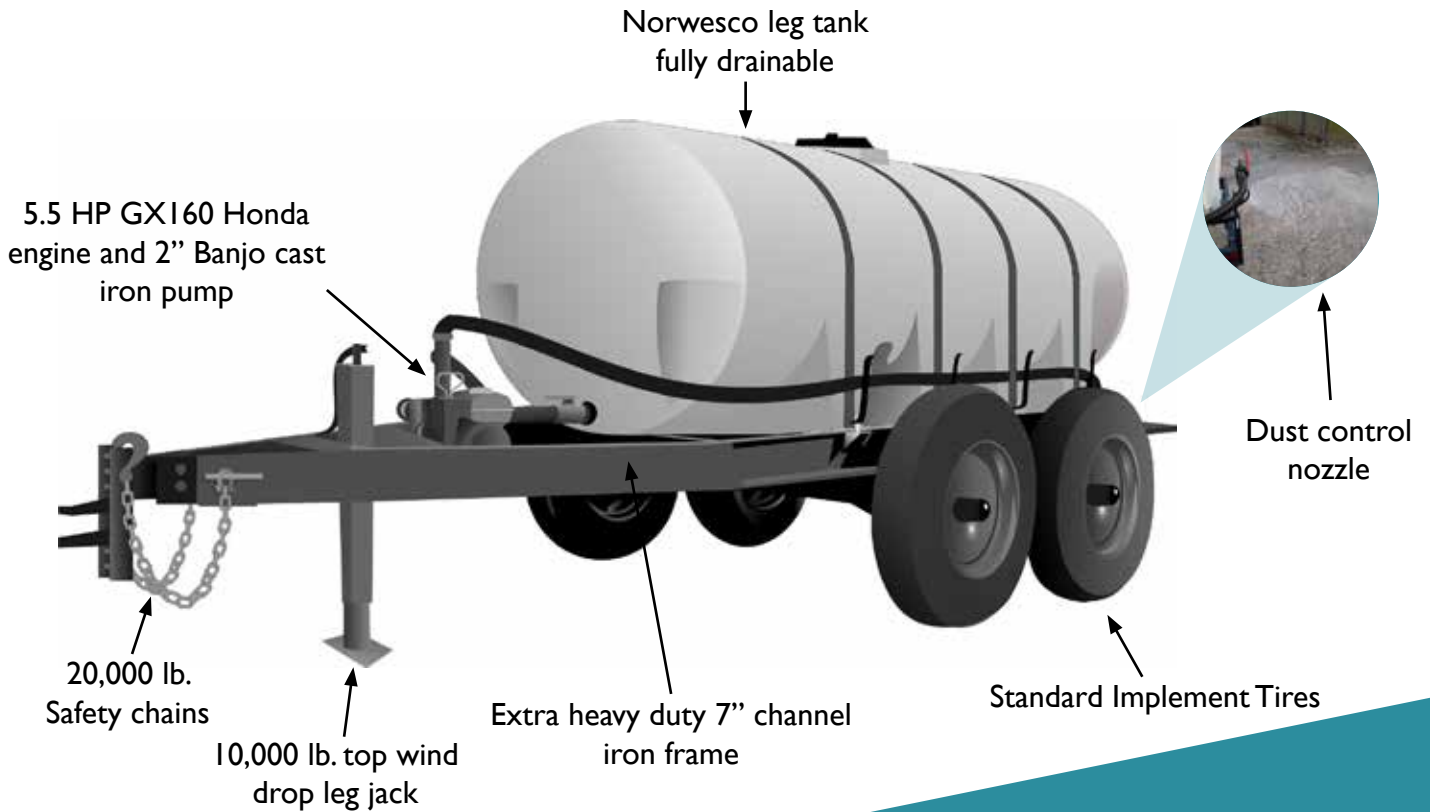

## Features & Benefits

- Reliable watering for jobsites, roadways, and arenas
- Powerful pump with 3 year warranty
- Easy to tow around racetracks, parks, and remote sites



## SPECIFICATIONS

### 1610 Gallon AquaDot Dust Suppression Trailer

Tank: Norwesco fully drainable tank

Frame: Extra heavy duty 7" channel iron frame, 5-year trailer frame warranty, Powder coat paint

Engine & Pump: 5.5 HP GX160 Honda engine and 2" Banjo cast iron pump

Axle: Slipper springs (tandem axle)

Tires: Standard implement tires 11L x 15 with 15 x 8" wheels 6-hole plugs

Tank Supports: Heavy duty cross member tank supports

Jack: 10,000 lb. top wind drop leg jack

Hitch: Choice of adjustable height hitch or standard clevis hitch

Warranty: 5 year frame warranty, 3 year non-prorated warranty on tank

Suspension: 5200 Lbs single torsion spring suspension

Spraying: Hose reel with stand

Size & Weight: 221"(L) x 77"(H) x 87" (W)



#### Includes:

- 5.5 HP GX160 Honda engine and 2" Banjo cast iron pump
- Recirculation plumbing kit to help control proper volume of water flow to dust control nozzle or hose bibb.
- Manual-rear dust control nozzle (No remote) -The powerful stainless steel spray nozzle is adjustable from 8' wide to 35' and spray approximately 25' deep from the rear. The nozzle is perfect for arenas, tracks, mining roads, parking areas.
- Hose bibb KIT - Pressure side, valve and 3/4" MGHT fitting - Hose bibb connection for customer to attach their own garden hose if needed.

# What makes AquaDot trailers different?



## We've got you covered

Very few (if any) of our competitors believe in their manufacturing process enough to offer a 5 year frame warranty and 1 year skid frame warranty. Our trailers are different; we take pride in providing the best product possible, delivered to your door. In addition to our manufacturer's frame warranty, we use only Norwesco tanks which provide a 3 year non-prorated tank warranty. Most all other tank manufacturers offer a prorated warranty, meaning if the tank is 75% through its warranty period that the warranty only covers 25% of the cost to replace the warranted tank. However, unlike the industry standard, **we use tanks with a non-prorated warranty.** What that means to you is that 100% of the tank is covered for the entire warranty period.

## Stronger than the average

While commonly used for water hauling and spraying, our trailers are actually built to withstand use with heavier liquids. This gives you flexibility and peace of mind in knowing that your multi-purpose trailer can safely handle whatever you need. They are built to safely haul liquids such as water-based fertilizers (up to 11 lbs/gallon), whereas water weighs only 8.32 lbs/gallon. The frame also has high strength and active use with a manufacturing process that avoids cutting the channel iron wherever possible. Instead, the iron is bent and formed into shape, eliminating common weak points that are common with many other trailer frames. To add extra strength and ensure that there are no frame issues where the channel iron is bent, we reinforce it along the outside edge as well.

## Things you don't see do matter

Have you ever purchased a trailer, only to find after a few months that rust is already showing? This results from a manufacturer that's more concerned with speed than with quality. You won't find that with AquaDot trailers. Our trailers get a good scrubbing before the powder coat paint finish is applied. Attention to even little details like this help ensure a long life for your trailer and are important to us.

## Freight savings, shorter lead times, delivered fully assembled

Select the shipping location that best fits your needs for freight and lead time. We ship from AL, AZ, CA, KS, KY, MN, ND, NE, WA. There's no need to wait for lead times of today's world - we always keep a supply of the AquaDot trailers in production.

For more complete information on One Clarion products and solutions, visit us on the web at: [www.clarionmunicipal.com](http://www.clarionmunicipal.com) or call us at : (+1) 863-261-8388 | [info@oneclarion.com](mailto:info@oneclarion.com)

© 2023 One Clarion. All rights reserved. One Clarion terms and conditions apply.



# Additional Dust Suppression Trailer and Skid Options

300, 525, 1010, and 1610 Gallon AquaDot Dust Suppression trailer	500 Gallon Elliptical AquaDot Dust Control Skid
<p>20' of 2" PVC suction hose kit with strainer, hose stand for suction</p> <p>12 Volt remote control sprayer on/off functionality</p> <p>Hose reel w/stand, 100' of 1" hose &amp; fire nozzle spray, approximately 50'-60' horizontal jet. 15'-20' vertical jet</p> <p>2" Ball coupler hitch, standard clevis hitch, 3" pintle ring (lunette eye) hitch</p> <p>Black tank upgrade for algae resistant tank, tank sight gauge for water levels</p> <p>DOT Package: Electric brakes, fenders, LED lighting, reflector, 10 ply highway rated tires</p>	<p>2" PVC Suction hose 20' kit with strainer- with or without stand.</p> <p>12 Volt remote control sprayer on/off functionality.</p> <p>1" Manual rewind hose reel</p> <p>50' of 1" EPDM Hose</p>



For more complete information on One Clarion products and solutions, visit us on the web at: [www.clarionmunicipal.com](http://www.clarionmunicipal.com) or call us at : (+1) 863-261-8388 | [info@oneclarion.com](mailto:info@oneclarion.com)

© 2023 One Clarion. All rights reserved. One Clarion terms and conditions apply.

