

TANK PLAN
SCALE: 1:100

MODEL	UR3D409
GROSS CAPACITY	49,600 GALLONS
NET CAPACITY	43,500 GALLONS
SHELL COLOR / FINISH	NO COLOR / GALVANIZED FINISH
SHELL MOISTURE BARRIER	20mil UNSUPPORTED PE
LINER	ENVIROLINER 20mil
ROOF SHEETING	CORRUGATED 2.67" PITCH 7/8" DEPTH

ID	ACCESSORIES
A1	30" HINGED ROOF ACCESS HATCH
A2	LIGHT DUTY LADDER - 3 RING TANK
A3	409" GEOMAT
A4	DUST AND VERMIN PROTECTION
A5	6" PVC OVERFLOW PIPEWORK
A6	MECHANICAL LEVEL GAUGE

NOTES

GENERAL

- DRAWINGS TO BE READ IN CONJUNCTION WITH DESIGN SPECIFICATION
- EFFECTIVE VOLUME CALCULATION BASED ON STORAGE LOSS BELOW INVERT OF THE LOWEST OUTLET AND FROM 1" BELOW THE INVERT / LIP OF THE LOWEST OVERFLOW

PRODUCTION

- ALL PIPEWORK & VALVES, UNLESS SPECIFIED, BY OTHERS

INSTALLATION

- ENSURE FIRM FLAT AND LEVEL SITE IS PROVIDED, AS PER SITE PREPARATION SPECIFICATION, PRIOR TO COMMENCING CONSTRUCTION
- ORIENTATION OF ALL FITTINGS TO BE CONFIRMED PRIOR TO INSTALLATION
- INSTALLATION TOLERANCES APPLY ON TOP OF STANDARD PRODUCTION TOLERANCES

INCHES	US GAL
87.0	49,600
85.5	48,700
82.5	47,000
79.5	45,300
76.5	43,600
73.5	41,900
70.5	40,200
67.5	38,500
64.5	36,800
61.5	35,100
58.5	33,300
55.5	31,600
52.5	29,900
49.5	28,200
46.5	26,500
43.5	24,800
40.5	23,100
37.5	21,400
34.5	19,700
31.5	18,000
28.5	16,200
25.5	14,500
22.5	12,800
19.5	11,100
16.5	9,400
13.5	7,700
10.5	6,000
7.5	4,300
4.5	2,600
1.5	900

Ø409" TANK DEPTH CHART

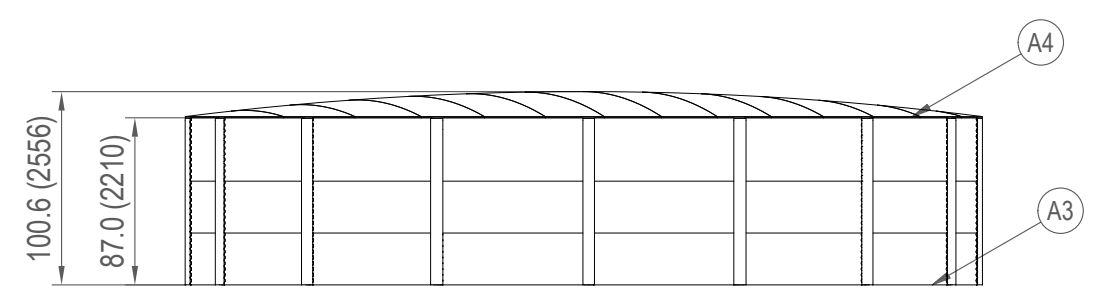

TANK ELEVATION
SCALE: 1:100

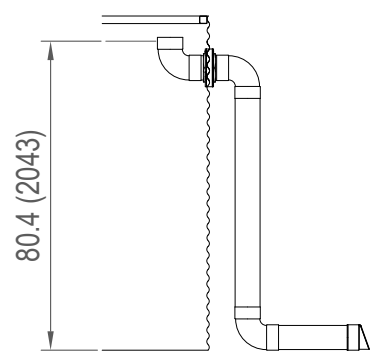

OVERFLOW
SCALE: 1:50

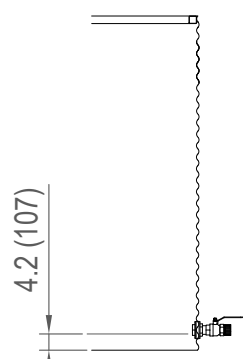

OUTLET
SCALE: 1:50

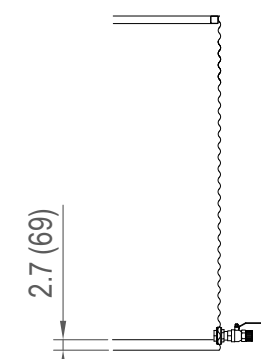

DRAIN
SCALE: 1:50

ID	DESCRIPTION	SIZE	TYPE	LVL.	MATERIAL	VALVE TYPE	INTERNAL
N1	OVERFLOW	6"	SDR 35	73.5	ASA	-	VERTICAL ORIFICE
N2	INLET	20"	BASKET	87.0	PP / PE	-	UV GUARD
N3	OUTLET	2"	Sch 40	5.25	GFN	Ni COATED BALL	HORIZONTAL ORIFICE
N4	DRAIN	2"	Sch 40	3.75	GFN	Ni COATED BALL	HORIZONTAL ORIFICE

REV.	DESCRIPTION	DATE	DRAWN	APPROVED
-1	FIRST ISSUE	18 NOV 16	BAF	---
REVISIONS				

ONE CLARION

www.clarionmunicipal.com
PO Box 700338
Wabasso, FL 32970
863-261-8388
info@oneclarion.com

	INIT.	DATE	DESCRIPTION
DRAWN BY	BAF	20161118	
CHECKED			
APPROVED			
ISSUED			

**50,000 GALLON TANK GENERAL ARRANGEMENT
PRODUCTION PART**

INCHES (MILLIMETRES)	SCALE	SHEET	Weight	PROJ. No.	DWG No.	REV.	SHEET SIZE
1 of 1	REFER SHEET	1 of 1		D035	U-10.4-1000-00001		B ANSI