

 1-863-261-8388

 info@oneclarion.com

 clarionmunicipal.com

TURBIDITY CURTAINS & BAFFLES

FLOATING CURTAINS & BAFFLES



Today's municipalities and industrial facilities are finding it difficult to stay in compliance with current discharge permits for waste water treatment systems because of increased growth, process design changes or fluctuating regulatory requirements.

Floating baffles offer an engineer the opportunity to create a flexible design to suit today's needs while still remaining open to change for possible long range requirements. Floating baffles are more cost efficient than any permanent dividers and can be installed in new or existing lagoons without the expense of dewatering or sludge removal. Floating baffles can be easily relocated within a lagoon as changing conditions require and flow-thru windows can be appropriately modified or relocated for any flow variation.

FLOATING CURTAINS & BAFFLES

Our custom manufactured floating baffles offer an easy and economical way to improve efficiency and effectiveness of any waste water treatment process which incorporates lagoons for surface control of floating materials; cooling ponds, settling basins or oxidation ponds. This is accomplished by creating side-to-side flow patterns that increase the retention time and eliminate short circuiting or channeling. Flow patterns can also be created top-to-bottom for a turnover effect.

Our floating baffles are manufactured from a variety of flexible thermoplastic coated (not laminated) reinforced fabrics. The fabrics are dielectrically sealed to form enclosures for the flotation logs, chain ballast and optional cable tension members. These items are connected by a skirt with the flotation logs at the surface and the chain at the lagoon bottom. Tension cable(s) are sometimes included in our floating baffles to provide added strength and to eliminate arcing.

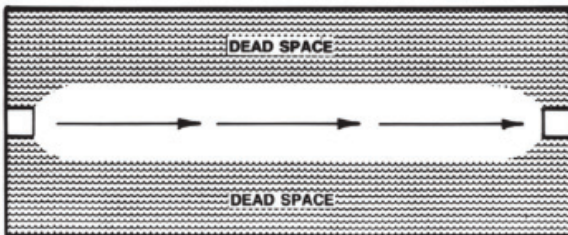

Short Circuiting Diagram

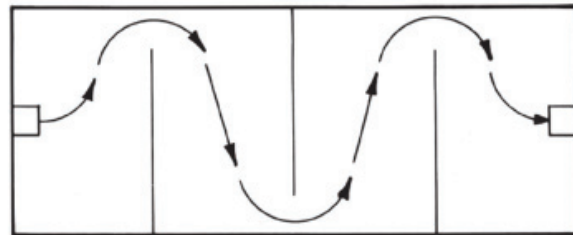

Side-to-Side Diversion Diagram

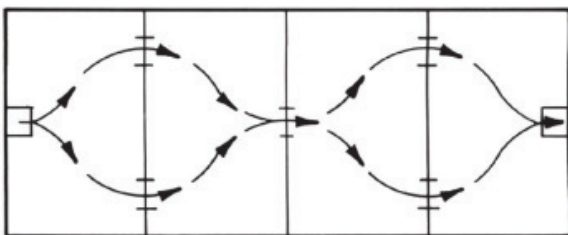

Flow-Thru Window Diversion Diagram

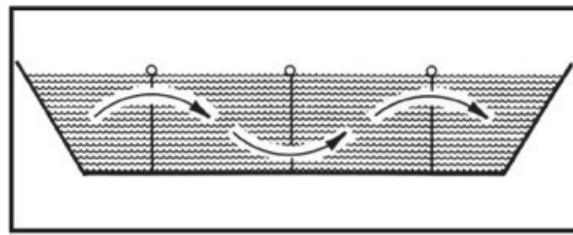

Top-To-Bottom Mixing Diagram

DOT TURBIDITY CURTAIN TYPES

TYPE I, II, III CURTAINS

One Clarion Environmental Turbidity Barriers and Silt Curtains are designed to provide proper compliance with the Clean Water Act and the National Pollution Discharge Elimination System (NPDES) requirements. These barriers are considered to be the most efficient method of compliance and we custom manufacture these according to all of our customers' specifications. Our barriers and curtains can be manufactured with both a solid fabric or filter screen skirt in an array of different sizes to fit your next project's exact needs!

TYPE I CURTAIN

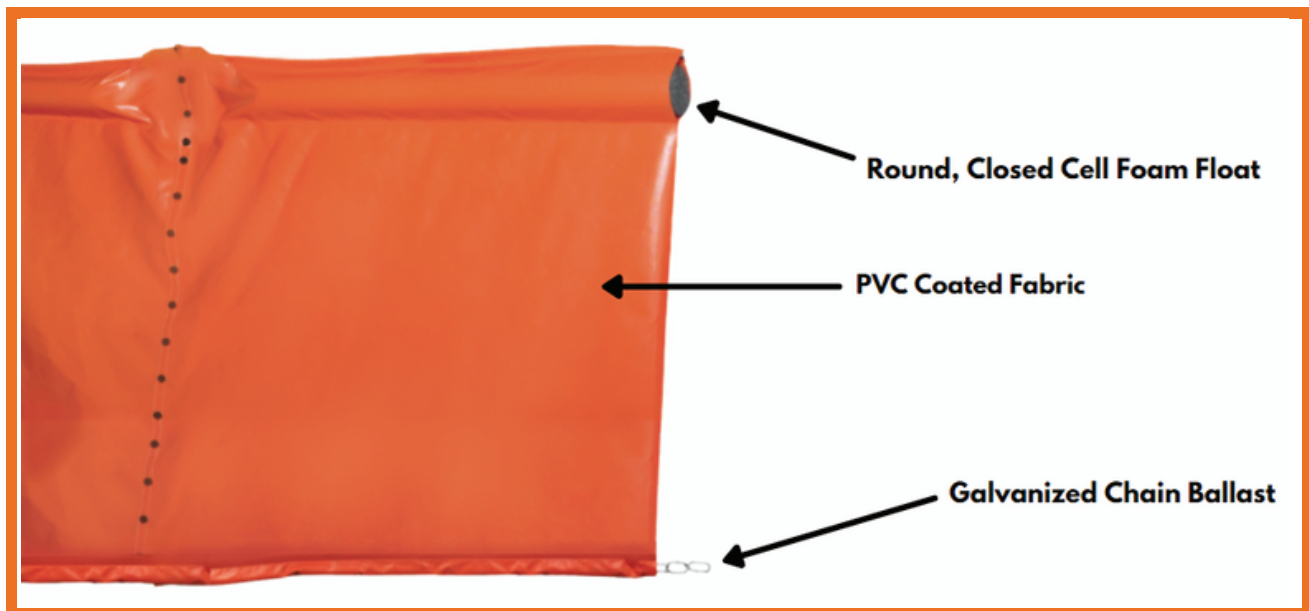

FOR CALM PROTECTED AREAS, SUCH AS LAKES WITH LITTLE OR NO CURRENT, THE TYPE I IS RECOMMENDED

DOT TURBIDITY CURTAIN TYPES

TYPE II CURTAIN

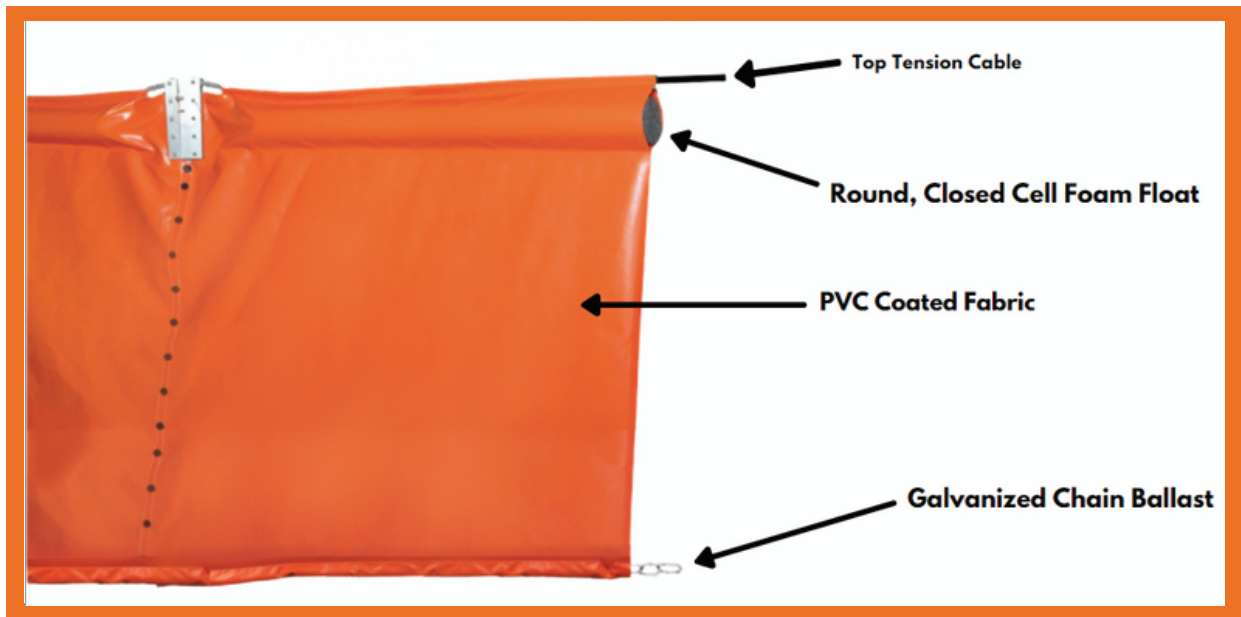

FOR STREAMS AND RIVERS WHERE THE CURRENT IS ONLY ONE-DIRECTIONAL, THE TYPE II IS RECOMMENDED

TYPE III CURTAIN

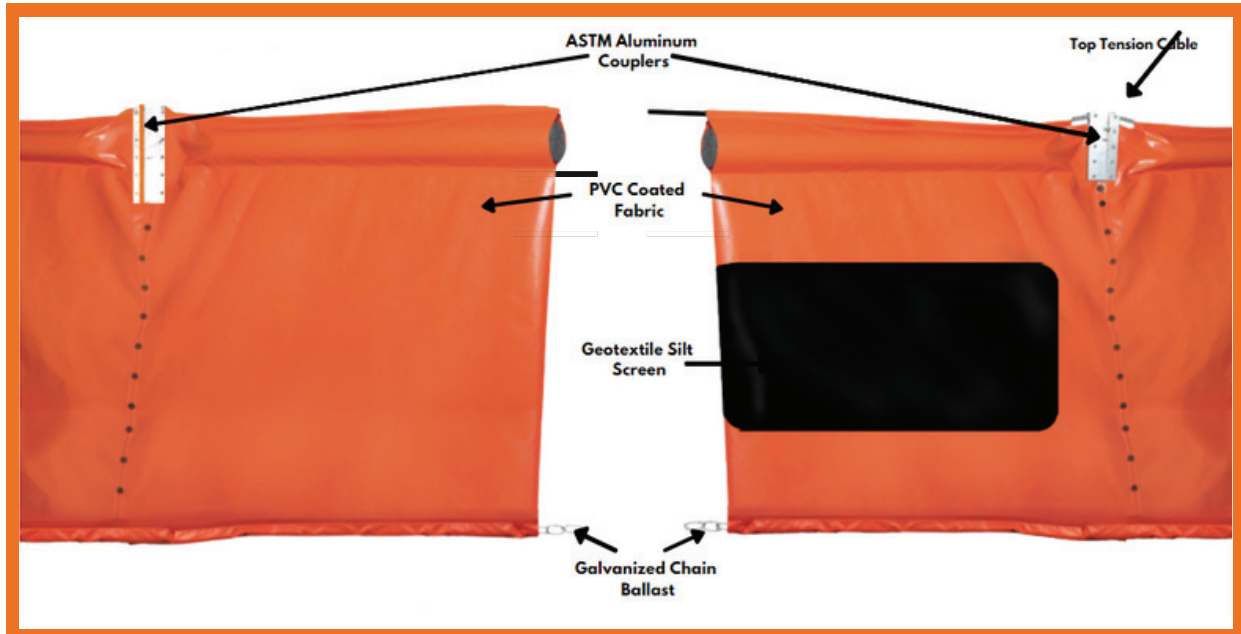

FOR TIDAL AREAS WHERE CURRENTS CHANGE DUE TO TIDAL AND WIND ACTION, THE TYPE III IS RECOMMENDED

PRINCIPAL COMPONENTS

MATERIALS

One Clarion offers a variety of fabrics to meet the various environments encountered by floating baffles. Tough woven fibers are saturated with primers making possible the molecular bonding of substrate and coating into a single system. There is NO delamination possible.

Competitive fabrics made of separate membranes and supporting fabric sandwiched together have no edge protection. Even with elaborate and frequently unpredictable edge sealing, liquids wick up the supporting fibers causing major degradation and delamination.

Impressive puncture resistance, tensile strength, abrasion resistance, dimensional stability and UV resistance are a function of all of our fabrics.

Coating compounds bond molecularly when heat welded and have proven to be stronger than the base fabric itself. Unlike some fabrics, our selected fabrics can be field repaired, by heat sealing, several years after installation.

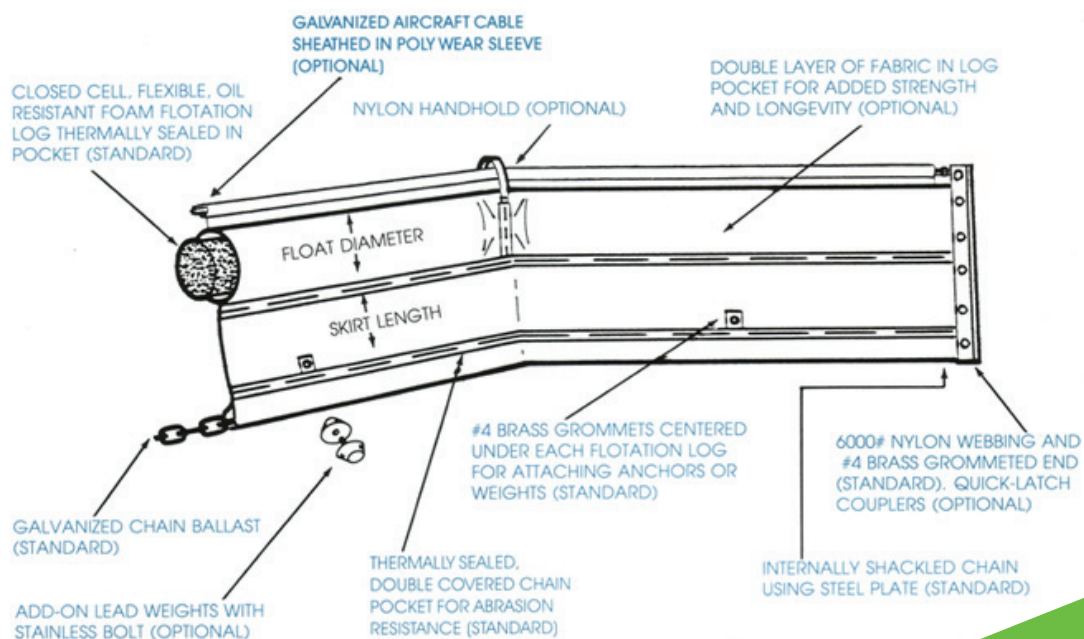

PRINCIPAL COMPONENTS

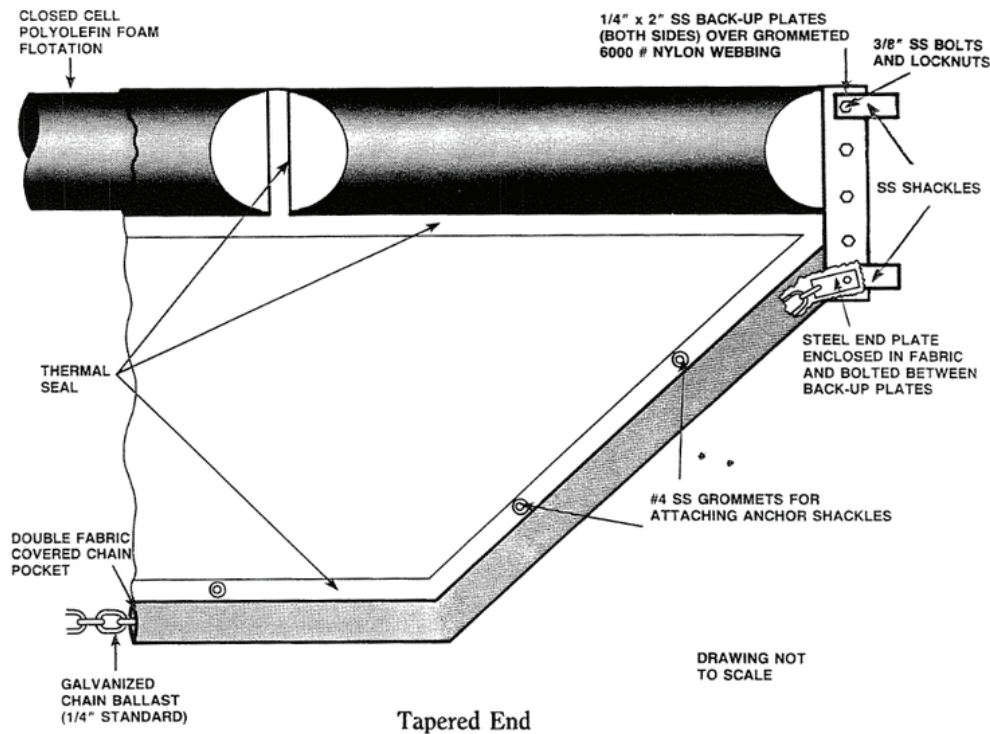

FLOTATION

Each floating baffle is designed to maintain appropriate freeboard height based on the length of the skirt and the size or type of skirt ballast. Flotation is provided using closed cell expanded polyolefin in diameters ranging from 4" to 12" with a buoyancy rating of 60 Lbs./Cu.Ft. Cylindrical flotation logs reduce wind load. Flotation logs are individually sealed inside fabric at intervals of approximately six feet to allow baffle to be folded for shipment and give it flexibility after installation. Individual float compartments also prevent the floats from moving inside the fabric cover, thus insuring uniform flotation along the entire length of the baffle. In the event the covering material is torn or severely abraded, the flotation logs will retain their buoyancy until repairs to the fabric can be made. The floats can be covered in two layers of fabric as an option.

PRINCIPAL COMPONENTS

SKIRT DEPTH

Skirt depths range from 1 foot to 30 feet depending on the requirements for each application.

BALLAST

Ballast is achieved by placing galvanized chain (generally 1/4" or 3/8") inside a dielectrically sealed pocket on the skirt bottom. This pocket consists of two layers of fabric for added abrasion resistance. If a tapered end (or ends) is included in the specifications for the baffle, the chain continues up the slope and connects to a galvanized steel plate (sealed within the chain pocket) that bolts between the endplates.

Ballast chain also serves as a tension member. Lead bar ballast (1/2" and 3/4" diameter), in place of chain, is available.

Grommets are added directly above the chain pocket when additional bottom anchoring is required. One inch wide stainless steel shackles are then bolted to the grommets to assist in attaching anchor weights.

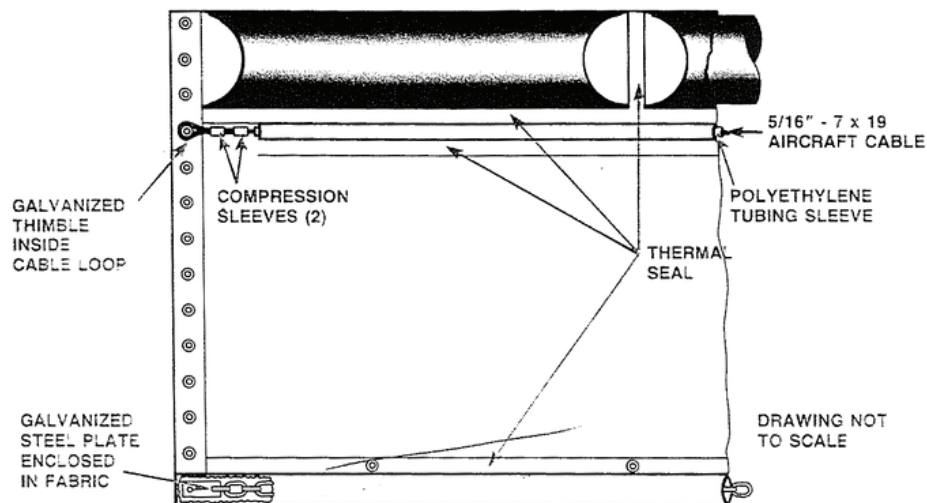

Square End - Single Tension Member (Section Coupler or Tie-Off)

PRINCIPAL COMPONENTS

TENSION MEMBERS

Baffle position is maintained by tensioning the ballast chain. 5/16" galvanized cable becomes a key tension member when sealed into its own pocket directly beneath the flotation logs. For baffles in excess of 1000 feet, a larger cable can be employed or a second

cable can be added above the flotation. Continuous tension is maintained evenly throughout by utilizing the ballast chain or the ballast chain and cable combination. Both of these tensioning devices are useful in minimizing arcing caused by wind and current.

END CONNECTORS

All One Clarion floating baffles have a heavy duty 2" wide, 6000# webbing stitched to a dielectrically sealed, folded-over end (four fabric layers). #4 stainless steel grommets are added on 3" centers along the entire length of each end. Mid-section ends are joined together with a pre-punched, 1/4" thick neoprene gasket placed between them and bolted together with 3/8" SS bolts, SS locknuts and SS washers (Flex Coupler). When a cable is part of the construction, thimbled cable ends are joined together at a coupler using a bolt, locknut and washers.

The design of the baffle end-connection plates can be adapted to any permanent anchoring facility. Unless otherwise specified, the end plates will be 1/4" stainless steel and secured to the grommeted reinforced baffle end with 3/8" SS bolts and locknuts. Two SS shackles are added and bolted to the baffle end back-up plates. These shackles provide two points of attachment to evenly distribute the tension forces on the end plates.

CUSTOMIZATION

FLOW-THROUGH WINDOWS

Baffles can be manufactured with windows sized and placed as required. Flow-thru windows can be modified or relocated to meet changing requirements. Size is based on the flow rate while desired flow patterns determine the location. All flow-thru windows are reinforced around the edges with additional skirt fabric. If significant fluctuations in flow rates cause extensive hydraulic pressure on a flow-thru window, additional material can be sealed or stitched around the edges of the window to increase strength. Maximum water velocity through a window should not exceed 30 Gal./Min./Sq.Ft. of opening.

Mid-depth separations are also available for controlling floating pollutants and settling of solids.

SECTION LENGTHS

When the total length of a specified baffle exceeds the maximum which is practical for shipping, the baffle is divided into sections 50 feet - 150 feet in length which are then joined together on the site. Individual section length is dependent upon flotation size and skirt length.



ADDITIONAL INFORMATION



ONE CLARION CURTAIN SERVICES

- ◆ Site inspections for applications and recommendations
- ◆ Installation advisors or complete installation service
- ◆ Maintenance and repair training
- ◆ Design work for unique applications

INVENTORY AND PURCHASING

Baffles are not kept in inventory because of all the numerous lengths, skirt depths, flotation sizes and optional accessories. Because baffles are custom manufactured, new ideas and configurations are no problem. To calculate the cost of a given job where alternatives are not included in our literature, submit sketches of desired design along with specifications and we will quote immediately.

Drawings and complete specifications covering materials to be used will be submitted by the baffle manufacturer for approval prior to production.