



## Deluxe Poultry House Sprayer Heavy Duty for Commercial & Farm Use

The Deluxe Poultry House Washer/Sprayer is equipped to meet the needs of today's producers. This trailer comes equipped with a 725 PSI, 39.6 GPM PTO driven diaphragm pump, and 5 nozzle wall washdown boom and ceiling nozzles. The unit also features 50' of 1/2" high pressure hose on self-retracting hose reel with high performance spray. Lastly, wheel fenders and a step make tank access easy. Besides keeping your poultry house clean, this trailer can also be equipped with a rear spray nozzle for dust control and other features that make it a multipurpose trailer.



# Features and Benefits

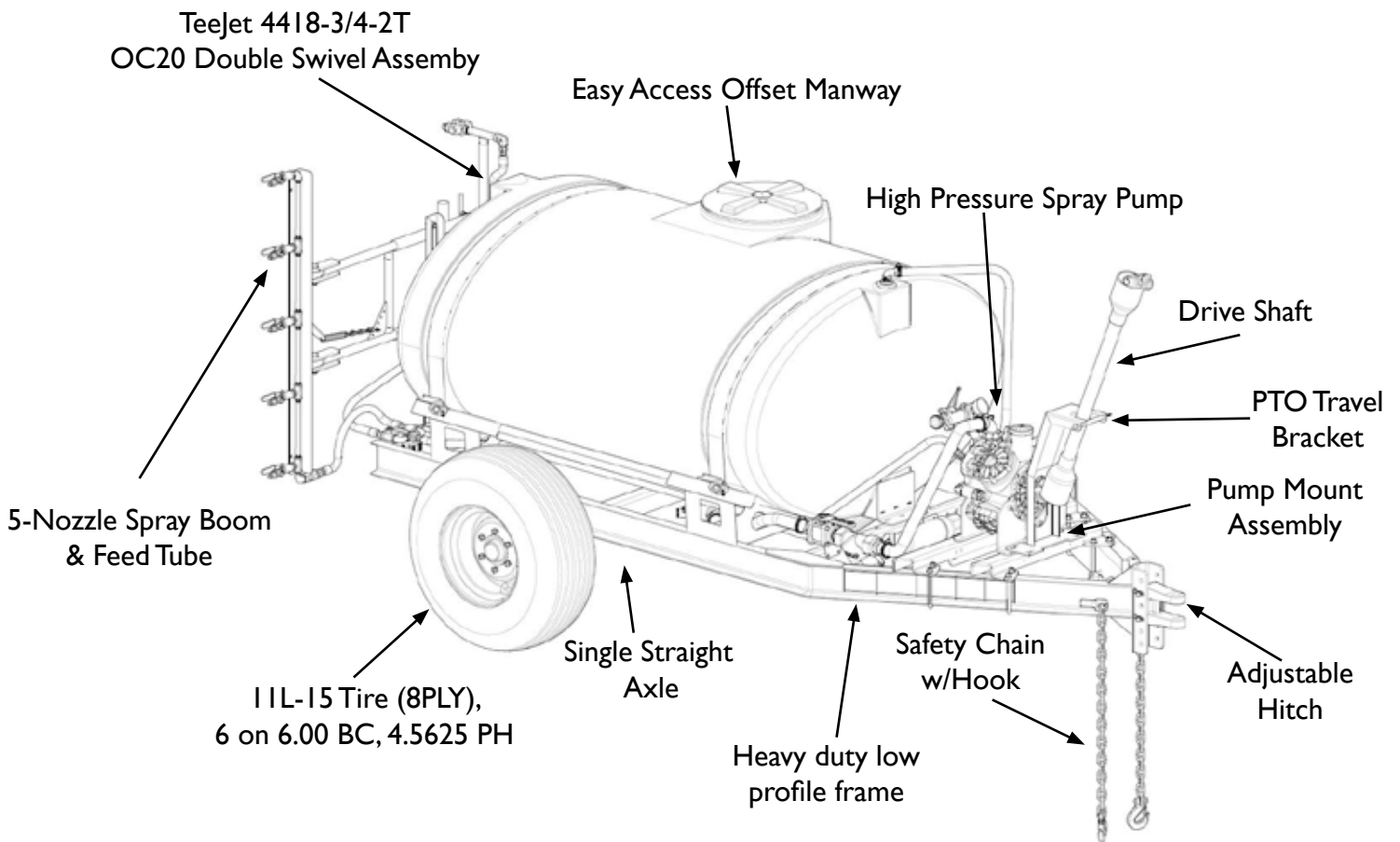

Features	Benefits
<ul style="list-style-type: none"> <li>• Diaphragm PTO 540 pump, 725PSI-39.6 gpm</li> <li>• High performance spray gun with 42" throw at 9.6 gpm</li> <li>• 5 nozzle adjustable wall boom</li> <li>• Bi-directional left or right wall boom</li> <li>• Ceiling spray nozzle</li> </ul>	<ul style="list-style-type: none"> <li>• Easy access offset manway on tank</li> <li>• Combines high pressure and water volume for fast and efficient cleaning.</li> <li>• Full cleaning with nozzles and booms that provide complete coverage</li> <li>• Low profile frame for better stability</li> </ul>

*We are here to serve you. Just call or email with your project specifications and details, and we'll do the rest. Our goal is to provide the best solution for your project, with materials delivered on time at a price that fits nicely within your budget.*



# Poultry House Sprayer

## Specifications

<b>Tank:</b>	500 gallon tank with easy access offset manway
<b>Supports:</b>	3" x 6" rectangular tubing cross member tank supports
<b>Frame:</b>	Heavy duty low profile frame
<b>Pump:</b>	725 psi, 39.6 gpm pto driven diaphragm pump
<b>Axle:</b>	Single straight axle (no suspension)
<b>Boom and nozzles:</b>	5 nozzle adjustable wall boom Bi-directional left of right wall boom Ceiling nozzle
<b>Jack:</b>	Heavy-duty jack that folds up within frame
<b>Extras:</b>	15,000 lb safety chains Adjustable clevis Fenders & side steps allow for easy access for tank fill ups
<b>Hose:</b>	50' 1/2" High pressure hose, with self-retracting hose reel 1/2" High pressure hose with quick disconnect couplers
<b>Warranty:</b>	5 year trailer frame warranty, 3 year tank warranty, and other components carry a 1 year warranty
<b>Optional:</b>	Fenders and side steps allow for easy tank fill ups Adjustable wide-angle stainless steel dust control spray nozzle

### Ask Us About Accessories!

- Pumps
- Engines
- Fittings
- Gauges
- Nozzles
- Tips
- Ladders
- Strainers
- Hose Reels
- Spray Guns
- Regulators
- Manifolds



For more complete information on One Clarion products and solutions, visit us on the web at: [www.clarionmunicipal.com](http://www.clarionmunicipal.com) or call us at : (+1) 863-261-8388 | [info@oneclarion.com](mailto:info@oneclarion.com)

© 2024 One Clarion. All rights reserved. One Clarion terms and conditions apply.

All photos are representative only. Actual products may differ. Materials and specifications are subject to change without notice. Featured products in photos may include additional equipment or accessories.

